



SJIII Compact Series Service Manual

Models 3215 & 3219

Skyjack Head Office 55 Campbell Rd. Guelph, Ontario N1H 1B9

Phone: 519-837-0888

Toll Free: 1-800-265-2738

Fax: 519-837-8104

Email: skyjack@skyjack.com

www.skyjack.com

Part No. 143909AA

USE THE SERIAL NUMBER OF YOUR MACHINE TO DETERMINE THE CORRECT OPERATING MANUAL TO USE

Manual Part #		117129AH	118941AI		143909AA
Release Date		August 2004	April 2007		April 2008
MODELS	3015	151981 & Below	Not Used		Not Used
	3215	Not Used	151982 to 154002	10 000 001 to 10 000 329	10 000 330 & Above
	3219	236285 & Below	236286 to 268399	22 000 001 & 22 013 837	22 013 838 & Above

113AA

Skyjack Service Center 3451 Swenson Ave. St. Charles, Illinois, 60174 USA

Phone: 630-262-0005
 Toll Free: 1-800-275-9522
 Fax: 630-262-0006
 Email: service@skyjack.com

Parts (North America)

Toll Free: 1-800-965-4626
 Toll Free Fax: 1-888-782-4825
 Email: parts@skyjack.com

Parts & Service (Europe) Glovers Meadow, Maesbury Rd. Oswestry, Shropshire, SY10 8NH UK

Phone: +44-1691-676-235
 Fax: +44-1691-676-238
 Email: info@skyjackeurope.co.uk

Skyjack Asia Pacific

Singapore
 Phone: +65-6449-3710
 Fax: +65-6449-7690
 Email: skyjack@singnet.com.sg

SERVICE AND MAINTENANCE

Table of Contents

Section 1 - Scheduled Maintenance Inspections

[Table of Contents](#)

Section 2 - Maintenance Tables

[Table of Content](#)

Section 3 - Schematics

[List of Contents](#)

Section 4 - Troubleshooting

[Troubleshooting](#)

Section 5 - Procedures

[List of Procedures](#)

[List of Tables](#)

The Safety Alert Symbol identifies important safety messages on aerial platforms, safety signs in manuals or elsewhere. When you see this symbol, be alert to the possibility of personal injury or death. Follow the instructions in the safety message.



This Safety Alert Symbol means attention!

Become alert! Your safety is involved.



DANGER

DANGER indicates an imminently hazardous situation which, if not avoided, will result in death or serious injury.



WARNING

WARNING indicates a potentially hazardous situation which, if not avoided, could result in death or serious injury.



CAUTION

CAUTION indicates a potentially hazardous situation which, if not avoided, may result in minor or moderate injury. It may also be used to alert against unsafe practices.

IMPORTANT

IMPORTANT indicates a procedure) essential for safe operation and which, if not followed, may result in a malfunction or damage to the aerial platform.

Section 1 SCHEDULE MAINTENANCE INSPECTIONS

Table of Contents

Operator’s Responsibility for Maintenance

- Aerial Platform Definition.....7
- Purpose of Equipment.....7
- Use of Equipment.....7
- Manuals.....7
- Operator.....7
- Service Policy and Warranty.....7
- Optional Accessories.....7
- Scope of this Manual.....8
- Operator Safety Reminders.....9
- Electrocution Hazard.....9
- Safety Precautions.....10
- Maintenance and Inspection Schedule.....13
- Owner’s Annual Inspection Record.....13
- Replacement Parts.....13
- Maintenance and Service Safety Tips.....13
- Hydraulic System & Component Maintenance and Repair.....14
- Maintenance Hints.....14

Service and Maintenance

- About this Section.....15
- Service Bulletins.....15
- Maintenance and Inspection.....15
- Maintenance Instructions.....15

Scheduled Maintenance

- 1.1 Scheduled Maintenance Inspections.....18
- 1.2 Function Tests.....25

Tables

- 1.1 Owner’s Annual Inspection Record.....16
- 1.2 Maintenance and Inspection Checklist.....17

SKYJACK is continuously improving and expanding product features on its equipment, therefore, specifications and dimensions are subject to change without notice.

Aerial Platform Definition

A mobile device that has an adjustable position platform supported from ground level by a structure.

Purpose of Equipment

The SKYJACK SJIII Compact and Conventional series aerial platforms are designed to transport and raise personnel, tools and materials to overhead work areas.

Use of Equipment

The aerial platform is a highly maneuverable, mobile work station. Lifting and driving must be on a flat, level, compacted surface. It can be driven over uneven terrain only when the platform is fully lowered.

Manuals

Operating

The operating manual is considered a fundamental part of the aerial platform. It is a very important way to communicate necessary safety information to users and operators. A complete and legible copy of this manual must be kept in the provided weather-resistant storage compartment on the aerial platform at all times.

Service & Maintenance

The purpose of this is to provide the customer with the servicing and maintenance procedures essential for the promotion of proper machine operation for its intended purpose.

All information in this manual should be read and understood before any attempt is made to service the machine. The updated copy of the manuals are found on the company's website: www.skyjack.com.

Operator

The operator must read and completely understand both this operating manual and the safety panel label located on the platform and all other warnings in this manual and on the aerial platform. Compare the labels on the aerial platform with the labels found within this manual. If any labels are damaged or missing, replace them immediately.

Service Policy and Warranty

SKYJACK warrants each new SJIII Series work platform to be free of defective parts and workmanship for the first 24 months. Any defective part will be replaced or repaired by your local SKYJACK dealer at no charge for parts or labor. Contact the SKYJACK Service Department for warranty statement extensions or exclusions.

Optional Accessories

The SKYJACK aerial platform is designed to accept a variety of optional accessories. These are listed under "Standard and Optional Features" in [Table 2.1](#) of the operating manual. Operating instructions for these options (if equipped) are located in [section 2](#) of the operating manual.

For non-standard components or systems, contact the SKYJACK Service Department at

North America & Asia:

☎ : 800 275-9522

📠 : 630 262-0006

Europe:

☎ : 44 1691-676-235

📠 : 44 1691-676-239

Include the model and serial number for each applicable aerial platform.

Scope of this Manual

- a. **This manual** applies to the ANSI/SIA, CSA and CE versions of the SJIII Series aerial platform models listed on [Table 2.1](#).
- **Equipment identified** with "ANSI" meets the ANSI SIA-A92.6-2006 standard.
 - **Equipment identified** with "CSA" meets the CSA B354.2-01 standard.
 - **Equipment identified** with "CE" meets the requirements for the European countries, i.e., Machinery Directive 98/37/EC and EMC Directive 89/336/EEC and the corresponding EN standards.
- b. **CSA (Canada) and CE (Europe)**
Operators are required to conform to national, territorial/provincial and local health and safety regulations applicable to the operation of this aerial platform.
- c. **ANSI/SIA (United States)**
Operators are required by the current ANSI/SIA A92.6 standards to read and understand their responsibilities in the manual of responsibilities before they use or operate this aerial platform.



WARNING

Failure to comply with your required responsibilities in the use and operation of the aerial platform could result in death or serious injury!

Operator Safety Reminders

A study conducted by St. Paul Travelers showed that most accidents are caused by the failure of the operator to follow simple and fundamental safety rules and precautions.

You, as a careful operator, are the best insurance against an accident. Therefore, proper usage of this aerial platform is mandatory. The following pages of this manual should be read and understood completely before operating the aerial platform.

Common sense dictates the use of protective clothing when working on or near machinery. Use appropriate safety devices to protect your eyes, ears, hands, feet and body.

Any modifications from the original design are strictly forbidden without written permission from SKYJACK Inc.

Electrocution Hazard

This aerial platform is not electrically insulated. Maintain a Minimum Safe Approach Distance (MSAD) from energized power lines and parts as listed below. The operator must allow for the platform to sway, rock or sag. This aerial platform does not provide protection from contact with or proximity to an electrically charged conductor.

**DO NOT USE AERIAL PLATFORM AS A GROUND FOR WELDING.
DO NOT OPERATE AERIAL PLATFORM DURING LIGHTNING OR STORMS.**

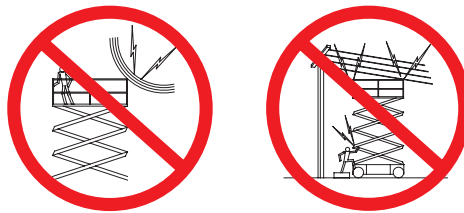

 <p>DANGER Avoid Power Lines</p>		
Minimum Safe Approach Distance		
ANSI/SIA A92.6-2006 and CSA B354.2-01 Requirements		CE Guidance Note “Avoidance of danger from overhead lines”
Voltage Range (Phase to Phase)	Minimum Safe Approach Distance (Feet)	Adhere strictly to the governmental rulings and regulations applicable in your country.
0 to 300V	Avoid Contact	
Over 300V to 50KV	10	
Over 50KV to 200KV	15	
Over 200KV to 350KV	20	
Over 350KV to 500KV	25	
Over 500KV to 750KV	35	
Over 750KV to 1000KV	45	
FAILURE TO AVOID THIS HAZARD WILL RESULT IN DEATH OR SERIOUS INJURY!		

60023AD

Safety Precautions

Know and understand the safety precautions before going on to next section.



WARNING

Failure to heed the following safety precautions could result in tip over, falling, crushing, or other hazards leading to death or serious injury.

- **KNOW** all national, state or territorial/provincial and local rules which apply to your aerial platform and jobsite.
- **TURN** emergency main power disconnect switch "O" off when leaving the aerial platform unattended. Remove the key to prevent unauthorized use of the aerial platform.
- **WEAR** all the protective clothing and personal safety devices issued to you or called for by job conditions.

- **DO NOT** wear loose clothing, dangling neckties, scarves, rings, wristwatches or other jewelry while operating this lift.

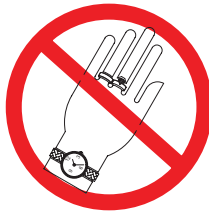

- **AVOID** entanglement with ropes, cords or hoses.



- **AVOID** falling. Stay within the boundaries of the guardrails.



- **DO NOT** raise the aerial platform in windy or gusty conditions.



- **DO NOT** increase the lateral surface area of the platform. Increasing the area exposed to the wind will decrease aerial platform stability.



- **DO NOT** drive or elevate the aerial platform if it is not on a firm level surface. Do not drive elevated near depressions or holes of any type, loading docks, debris, drop-offs and surfaces that may affect the stability of the aerial platform.



- **If operation in areas with holes or drop-offs is absolutely necessary**, elevated driving shall not be allowed. Position the aerial platform horizontally only with the platform fully lowered. After ensuring that all 4 wheels or outriggers (if equipped) have contact with level firm surface, the aerial platform can be elevated. After elevation, the drive function must not be activated.



- **Elevated driving** must only be done on a firm level surface.



- **DO NOT** ascend or descend a grade when elevated. When fully lowered, ascending or descending, only grades up to rated maximum listed in [Table 2-3a](#) and [Table 2-3b](#) are permissible.



Safety Precautions (Continued)

Know and understand the safety precautions before going on to next section.

- **DO NOT** operate on surfaces not capable of holding the weight of the aerial platform including the rated load, e.g. covers, drains, and trenches.

- **DO NOT** operate an aerial platform that has ladders, scaffolding or other devices mounted on it to increase its size or work height. It is prohibited.



- **DO NOT** exert side forces on aerial platform while elevated.



- **DO NOT** use the aerial platform as a crane. It is prohibited.



- **DO NOT** sit, stand or climb on the guardrails. It is prohibited.



- **DO NOT** climb on scissor arm assembly. It is prohibited.



- **BE AWARE** of overhead obstructions or other possible hazards around the aerial platform when driving or lifting.

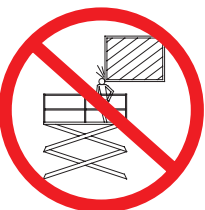

- **DO NOT** raise the aerial platform while the aerial platform is on a truck, fork lift or other device or vehicle.



- **BE AWARE** of crushing hazards. Keep all body parts inside platform guardrail.

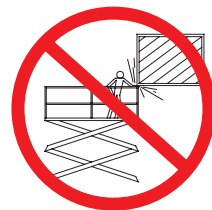

- **DO NOT** lower the platform unless the area below is clear of personnel and obstructions.

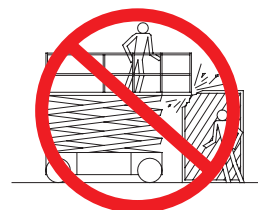

- **ENSURE** that there are no personnel or obstructions in the path of travel, including blind spots.

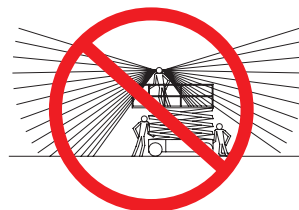

- **BE AWARE** of blind spots when operating the aerial platform.

- **STUNT** driving and horseplay are prohibited.

- **ENSURE ALL** tires are in good condition and lug nuts are properly tightened.

- **DO NOT** alter or disable limit switches or other safety devices.

- **DO NOT** use the aerial platform without guardrails, locking pins and the entry gate in place.

Safety Precautions (Continued)

Know and understand the safety precautions before going on to next section.

- **DO NOT** exceed the rated capacity of the aerial platform. Do make sure the load is evenly distributed on the platform.
- **DO NOT** attempt to free a snagged platform with lower controls until personnel are removed from the platform.
- **DO NOT** position the aerial platform against another object to steady the platform.
- **DO NOT** place materials on the guardrails or materials that exceed the confines of the guardrails unless approved by Skyjack.

Fall Protection

As per the ANSI A92.6-2006 standard, "The guardrail system of the aerial platform provides fall protection. If occupant(s) of the platform are required to wear personal fall protection equipment (PFPE), occupants shall comply with instructions provided by the aerial platform manufacturer (remanufacturer) regarding anchorage(s)."

If additional fall protection is required, by an employer or the authority having jurisdiction, Skyjack recommends the use of a fall restraint system to keep an occupant within the confines of the platform, and thus not expose the occupant to any fall hazard requiring a fall arrest.

All personal fall protection equipment must comply with applicable governmental regulations and must be inspected and used in accordance with the manufacturer's recommendations.

All personal fall protection equipment must be attached only to approved anchorage points within the platform of the aerial platform.



WARNING

Entering and exiting the aerial platform should only be done using the three points of contact.

- Use only equipped access openings.
- Enter and exit only when the aerial platform is in the fully retracted position.
- Do use three points of contact to enter and exit the platform. Enter and exit the platform from the ground only. Face the aerial platform when entering or exiting the platform.
- Three points of contact means that two hands and one foot or one hand and two feet are in contact with the aerial platform or the ground at all times during entering and exiting.



WARNING

An operator should not use any aerial platform that:

- does not appear to be working properly.
- has been damaged or appears to have worn or missing parts.
- has alterations or modifications not approved by the manufacturer.
- has safety devices which have been altered or disabled.
- has been tagged or blocked out for non-use or repair.

Failure to avoid these hazards could result in death or serious injury.

Jobsite Inspection

- Do not use in hazardous locations.
- Perform a thorough jobsite inspection prior to operating the aerial platform, to identify potential hazards in your work area.
- Be aware of moving equipment in the area. Take appropriate actions to avoid collision.

Maintenance and Inspection Schedule

The actual operating environment of the work platform governs the use of the maintenance schedule. The inspection points covered in [Table 1.2](#). Maintenance and Inspection Checklist, indicates the areas of the aerial platform to be maintained or inspected and at what intervals the maintenance and inspections are to be performed.

Owner's Annual Inspection Record

It is the responsibility of the owner to arrange quarterly and annual inspections of the aerial platform. [Table 1.1](#). Owner's Annual Inspection Record is to be used for recording the date of the inspection, owner's name, and the person responsible for the inspection of the work platform.

Replacement Parts

Use only original replacement parts. Parts such as batteries, wheels, railings, etc. with weight and dimensions different from original parts will affect stability of the work platform and must not be used without manufacturer's consent.

Use only original filled tires for models which must be so equipped. Consult factory.

All replacement tires must be of the same size and load rating as original equipment to maintain safety and stability of the work platform. Consult factory.



WARNING

Any unit that is damaged or not operating properly must be immediately tagged and removed from service until proper repairs are completed.

Maintenance and Service Safety Tips

Maintenance and repair should only be performed by personnel who are trained and qualified to service this aerial platform.

All maintenance and service procedures should be performed in a well lighted and well ventilated area.

Anyone operating or servicing this aerial platform must read and completely understand all operating instructions and safety hazards in this manual and operating manual.

All tools, supports and lifting equipment to be used must be of proper rated load and in good working order before any service work begins. Work area should be kept clean and free of debris to avoid contaminating components while servicing.

All service personnel must be familiar with employer and governmental regulations that apply to servicing this type of equipment.

Keep sparks and flames away from all flammable or combustible materials.

Properly dispose of all waste material such as lubricants, rags, and old parts according to the relative law provisions obtaining in the country.

Before attempting any repair work, turn Battery Disconnect Switch to the "OFF" position.

Preventive maintenance is the easiest and least expensive type of maintenance.

Hydraulic System & Component Maintenance and Repair

The following points should be kept in mind when working on the hydraulic system or any component:

1. Any structure has limits of strength and durability. To prevent failure of structural parts of hydraulic components, relief valves which limit pressure to safe operating values are included in the hydraulic circuits.
2. Tolerance of working parts in the hydraulic system is very close. Even small amounts of dirt or foreign materials in the system can cause wear or damage to components, as well as general faulty operation of the hydraulic system. Every precaution must be taken to assure absolute cleanliness of the hydraulic oil.
3. Whenever there is a hydraulic system failure which gives reason to believe that there are metal particles or foreign materials in the system, drain and flush the entire system and replace the filter cartridges. A complete change of oil must be made under these circumstances.
4. Whenever the hydraulic system is drained, check the magnets in the hydraulic reservoir for metal particles. If metal particles are present, flush the entire system and add a new change of oil. The presence of metal particles also may indicate the possibility of imminent component failure. A very small amount of fine particles is normal.
5. All containers and funnels used in handling hydraulic oil must be absolutely clean. Use a funnel when necessary for filling the hydraulic oil reservoir, and fill the reservoir only through the filter opening. The use of cloth to strain the oil should be avoided to prevent lint from getting into the system.
6. When removing any hydraulic component, be sure to cap and tag all hydraulic lines involved. Also, plug the ports of the removed components.
7. All hydraulic components must be dis-assembled in spotlessly clean surroundings. During disassembly, pay particular attention to the identification of parts to assure proper reassembly. Clean all metal parts in a clean mineral oil solvent. Be sure to thoroughly clean all internal passages. After the parts have been dried thoroughly, lay them on a clean, lint-free surface for inspection.
8. Replace all O-rings and seals when overhauling any component. Lubricate all parts with clean hydraulic oil before reassembly. Use small amounts of petroleum jelly to hold O-rings in place during assembly.
9. Be sure to replace any lost hydraulic oil when completing the installation of the repaired component, and bleed any air from the system when required.
10. All hydraulic connections must be kept tight. A loose connection in a pressure line will permit the oil to leak out or air to be drawn into the system. Air in the system can cause damage to the components and noisy or erratic system operation.

Maintenance Hints

Three simple maintenance procedures have the greatest effect on the hydraulic system performance, efficiency and life. Yet, the very simplicity of them may be the reason they are so often overlooked. What are they? Simply these:

1. Change filters annually. The filters will need to be changed more often depending on the operating conditions. Dirty, dusty, high moisture environments may cause the hydraulic system to be contaminated more quickly.
2. Maintain a sufficient quantity of clean hydraulic oil of the proper type and viscosity in the hydraulic reservoir.
3. Keep all connections tight.

About this Section

This section contains the maintenance and inspection schedule that is to be performed.

References are made to the procedures in Section 5 that outline detailed step-by-step instructions for checks and replacements.

Service Bulletins

Before performing any scheduled maintenance inspection procedure, refer to service bulletins found in our web site: www.skyjackinc.com for updates related to service and maintenance of this aerial platform.

Maintenance and Inspection

Death or injury can result if the aerial platform is not kept in good working order. Inspection and maintenance should be performed by competent personnel who are trained and qualified on maintenance of this aerial platform.

**WARNING**

Failure to perform each procedure as presented and scheduled may cause death, serious injury or substantial damage.

NOTE

Preventive maintenance is the easiest and least expensive type of maintenance.

- Unless otherwise specified, perform each maintenance procedure with the aerial platform in the following configuration:
 - Aerial platform parked on a flat and level surface
 - Disconnect the battery by turning the main power disconnect switch to the “OFF” position.
- Repair any damaged or malfunction components before operating aerial platform.
- Keep records on all inspections.

Maintenance Instructions

This manual consists of four schedules to be done for maintaining on an aerial platform. Inspection schedule frequency is shown below:

Inspection Schedule

Daily	A
Frequently	A + B
Annually	A + B + C
Bi-annually	A + B + C + D

- Make copies of the maintenance and inspection checklist to be used for each inspection.
- Check the schedule on the checklist for the type of inspection to be performed.
- Place a check in the appropriate box after each inspection procedure is completed.
- Use the maintenance and inspection checklist and step-by-step procedures in [Section 5](#) to perform these inspections.
- If any inspection receives a fail, tag and remove the aerial platform from service.
- If any aerial platform component(s) has been repaired, an inspection must be performed again before removing the tag. Place a check in the repair column.

Legend

P = Pass
F = Fail
R = Repaired

Table 1.1 Owner’s Annual Inspection Record

Model Number: _____		Serial Number: _____							
Recording Date									
Recording Year #	1	2	3	4	5	6	7	8	9
Owner’s Name									
Inspected By									

60564AA

As described earlier in this section, this decal is located on the control compartment cowling. It must be completed after an annual inspection has been completed. Do not use the aerial platform if an inspection has not been recorded in the last 13 months.



Table 1.2 MAINTENANCE AND INSPECTION CHECKLIST

Serial Number: _____
 Model: _____
 Hourmeter Reading: _____
 Date: _____
 Time: _____

Operator's Name (Printed): _____
 Operator's Signature: _____

Each item shall be inspected using the the appropriate section of the Skyjack operating manual.
 As each item is inspected, write the appropriate grade in the box.

P - PASS
F - FAIL
R - REPAIRED

INSPECTION FREQUENCY

- DAILY
- FREQUENTLY
- ANNUALLY
- BI-ANNUALLY

Inspection Schedule	
Daily	A
Frequently*	A + B
Annually	A + B + C
Bi-annually	A + B + C + D

Schedule	P	F	R
Schedule Maintenance Inspections			
Labels	A		
Limit Switches	A, B		
Entrance Side			
Main Power Disconnect Switch	A, B		
Base Control Switches	A, B		
Free-wheeling Valve Knob (Compacts - Front Side)	A, B		
Brakes	A, B, C		
AC Outlet Receptacle	A, B		
Ladder	A, B		
Engine Compartment			
Engine Control Console	A, B		
Radiator	A, B, C		
Muffler and Exhaust	A, B		
Engine Tray	A, B		
Hydraulic Pump	A, B		
Engine Air Filter	A, B		
Engine Oil Level	A, B		
Engine Fuel Filter	A, B, C		
Battery Tray Side			
Pothole Protection Device	A, B		
Battery Tray	A, B		
Battery Charger	A, B		
Battery	A, B		
Steer Cylinder Assembly	A, B		
Wheel/Tire Assembly	A, B		
Tie Rod (Conventionals)	A, B		
Greasing Points	A, B, C		
Hydraulic/Electric Tray Side			
Pothole Protection Device	A, B		
Hydraulic Tank	A, B, C		
Hydraulic Oil	A, B, C		
Hydraulic Pump and Motor	A, B		
Electrical Panel	A, B		
Proportional and Main Manifolds	A, B		
Tilt Sensor (If Equipped)	A, B		

Schedule	P	F	R
Load/Tilt Sensor - CE	A, B		
Emergency Lowering Access Rod (If Equipped)	A, B		
Platform Assembly			
Lanyard Attachment Anchors	A, B		
AC Outlet on Platform	A, B		
Platform Control Console	A, B		
Manual	A, B		
Powered Extension Control Console (If Equipped)	A, B		
Lift Mechanism			
Maintenance Support	A, B		
Scissor Assembly	A, B		
Scissor Bumpers	A, B		
Rollers	A, B		
Lift Cylinder(s)	A, B		
Function Tests			
Test Main Power Disconnect Switch	A, B		
Base Control Console			
Test Base Emergency Stop	A, B		
Test Off/Platform/Base	A, B		
Test Lower/Neutral/Raise Switch	A, B		
Test Emergency Lowering	A, B		
Test Free-wheeling	A, B		
Platform Control Console			
Test Platform Emergency Stop	A, B		
Test Enable Trigger Switch	A, B		
Test Steering	A, B		
Test Driving	A, B		
Test Brakes	A, B		
Test Brake	A, B		
Test Platform Raising/Lowering	A, B		
Test Lowering Warning - CE	A, B		
Test Powerdeck Enable	A, B		
Test Speed Limit	A, B		
Test Tilt Sensor (If Equipped)	A, B		

111AA

- A** - Perform Visual and Daily Maintenance Inspections & Functions Test. Refer to [Section 2.7](#) of the Operating Manual.
- B** - Perform Scheduled Maintenance Inspection every three months or 150 hrs. Refer to [Section 1.0](#) of this manual.
- C** - Perform Scheduled Maintenance Inspection every year. Refer to [Section 1.0](#) of this manual.
- D** - Perform Scheduled Maintenance Inspection every 2 years. Refer to [Section 1.0](#) of this manual.

* Perform scheduled inspection every three months or 150 hours.

Note: Make a copy of this page or visit the Skyjack web site:www.skyjack.com for a printable copy.

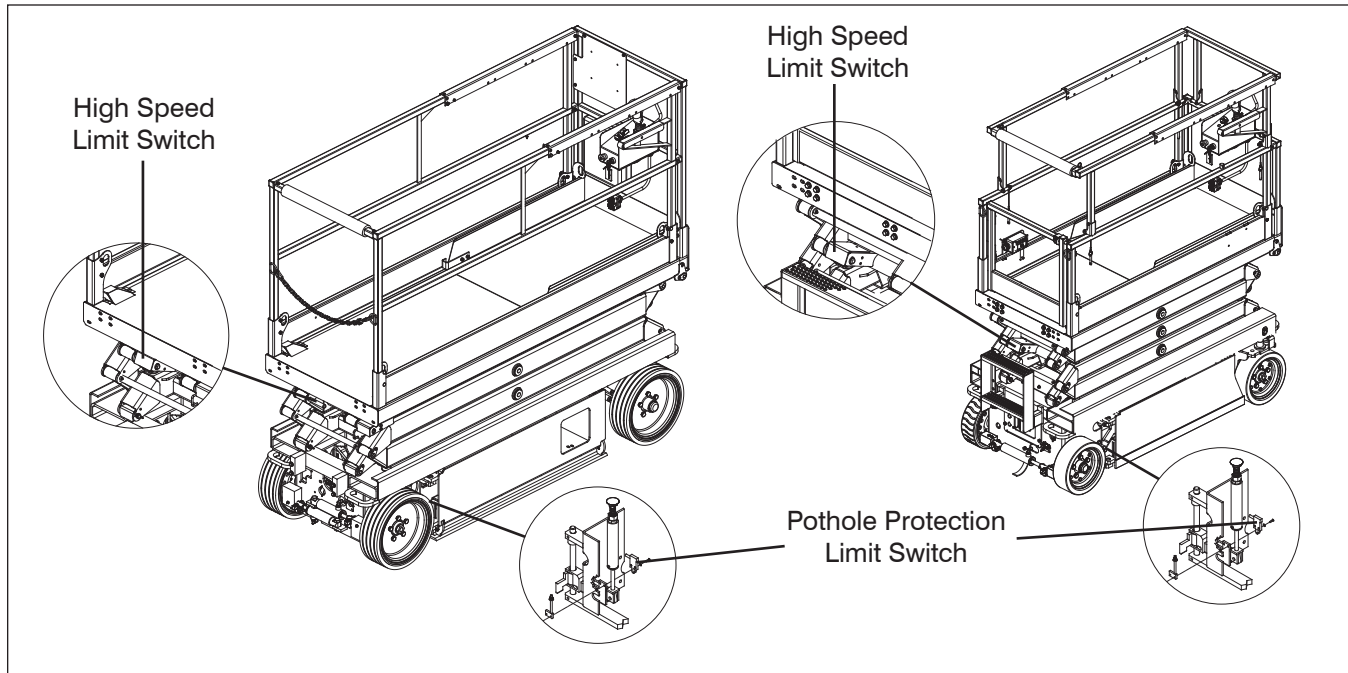

1.1 Scheduled Maintenance Inspections

Begin the scheduled maintenance inspections by checking each item in sequence for the conditions listed in this section.



WARNING

To avoid injury, do not operate an aerial platform until all malfunctions have been corrected.



WARNING

To avoid possible injury, ensure aerial platform power is off during your visual and daily maintenance inspections.

Electrical

Maintaining the electrical components is essential to good performance and service life of the aerial platform.

Inspect the following areas for chafed, corroded and loose wires:

- base to platform cables and wiring harness
- battery tray wiring harnesses
- hydraulic/electrical wiring harnesses

Hydraulic

Maintaining the hydraulic components is essential to good performance and service life of the aerial platform.

Perform a visual inspection around the following areas:

- hoses and fittings
- all hydraulic cylinders
- all hydraulic manifolds
- the underside of the base
- ground area under the aerial platform

1.1-1 Labels

Refer to the labels section in this manual and determine that all labels are in place and are legible.

1.1-2 Limit Switches

Detecting limit switch malfunction is essential to safe aerial platform operation. Ensure limit switches are properly secured and movement is not obstructed.

Visually inspect all limit switch located inside the scissor arms and the outrigger assemblies for the following:

- broken or missing actuator arm
- missing fasteners
- loose wiring

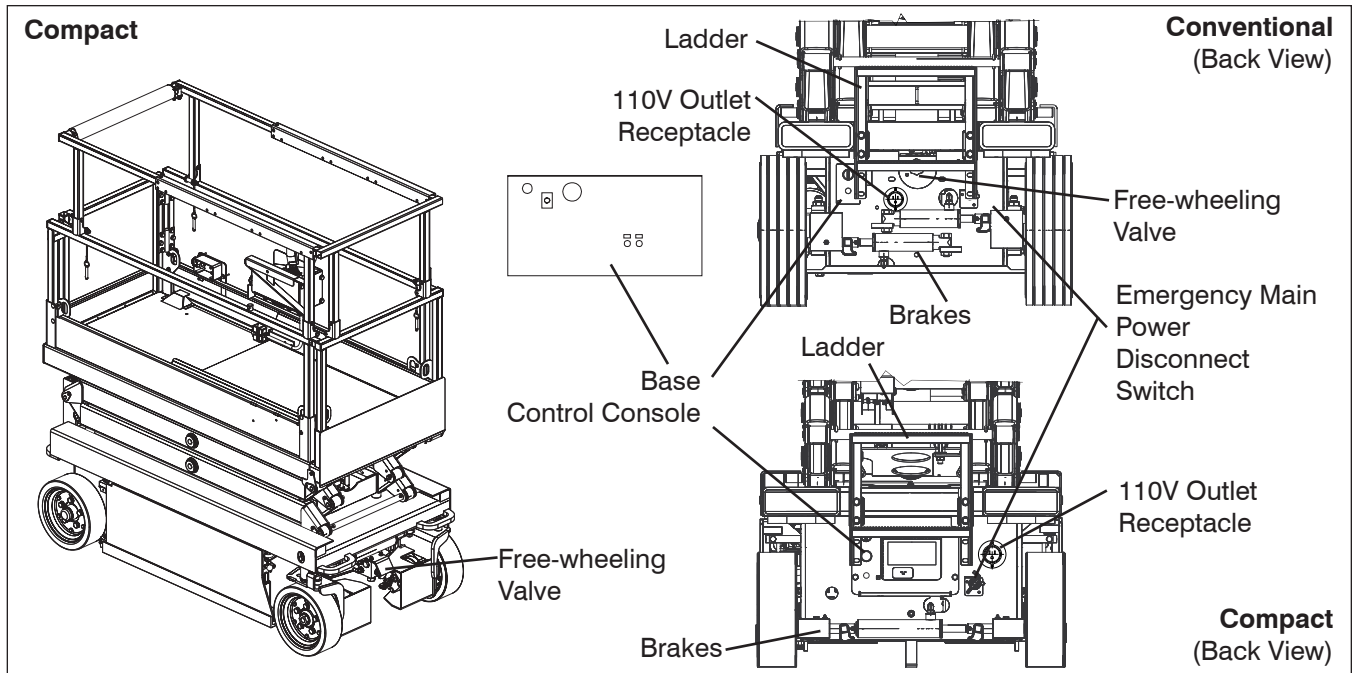

1.1-3 Entrance Side

- **Main Power Disconnect Switch**
 - Turn emergency main power disconnect switch to “O” off position.
 - Ensure all cables are secure and switch is in proper working condition.
- **Base Control Switches**
 - Ensure there are no signs of visible damage and all switches are in their neutral positions.
- **Free-wheeling Valve Knob**
(Compacts - Front Side)
 - Ensure there are no loose or missing parts and there is no visible damage.
- **Brakes**
 - Ensure there are no loose or missing parts and there is no visible damage.
 - Ensure tabs are not locked.
- **AC Outlet Receptacle**
 - Ensure receptacle is free from dirt and obstructions.
- **Ladder**
 - Ensure there are no loose or missing parts and there is no visible damage.

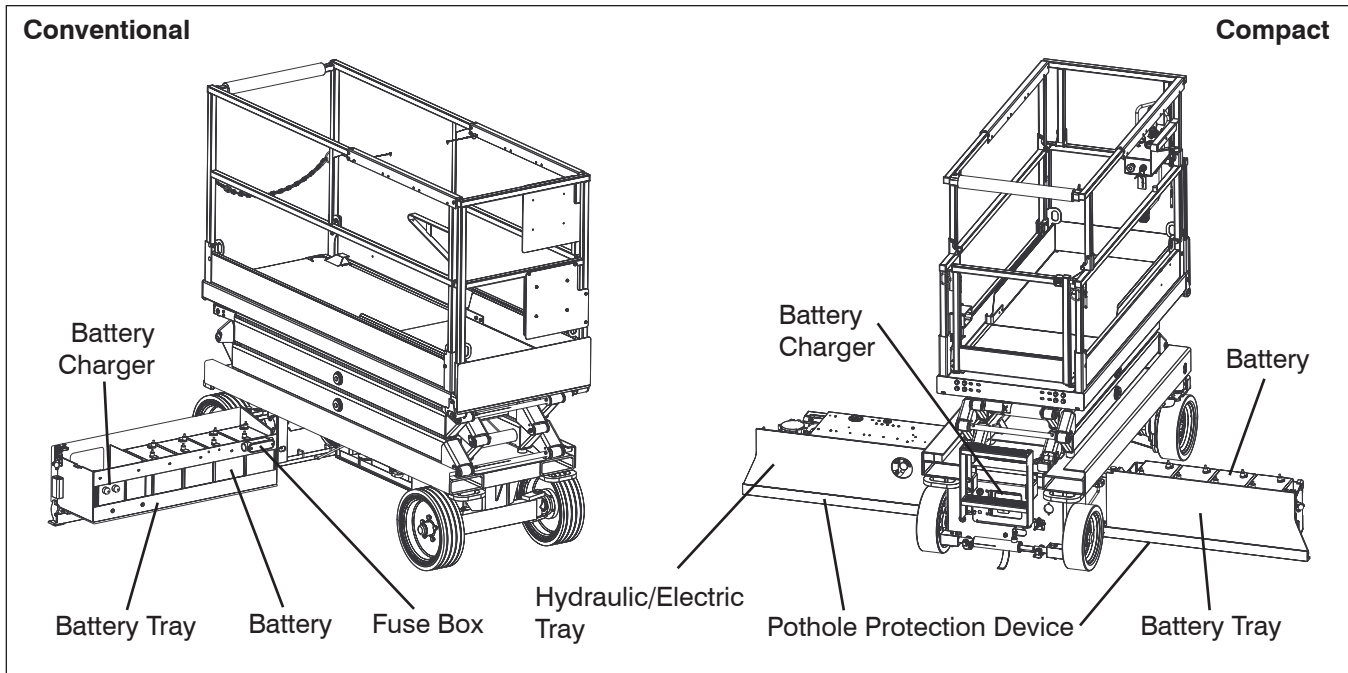

1.1-4 Battery Tray Side

- **Pothole Protection Device**
 - Ensure mechanisms have no sign of visible damage and are free from dirt and obstructions.
- **Battery Tray**
 - Ensure tray latch is secure and in proper working order.
- **Battery Charger**
(Compacts - Entrance Side)
 - Ensure charger is secure and shows no visible damage.
- **Battery**
Proper battery condition is essential to good performance and operational safety. Improper fluid levels or damaged cables and connections can result in component damage and hazardous conditions.

 **WARNING**

Battery acid is extremely corrosive - Wear proper eye and facial protection as well as appropriate protective clothing. If contact occurs, immediately flush with cold water and seek medical attention.

1. Check battery case for damage.
2. Clean battery terminals and cable ends thoroughly with a terminal cleaning tool or wire brush.
3. Ensure all battery connections are tight.
4. If applicable, check battery fluid level. If plates are not covered by at least 1/2" (13 mm) of solution, add distilled or demineralized water.
5. Replace battery if damaged or incapable of holding a lasting charge.

 **WARNING**
Explosion hazard. Keep flames and sparks away. Do not smoke near batteries. 

 **WARNING**
Use original or manufacturer-approved parts and components for the aerial platform.

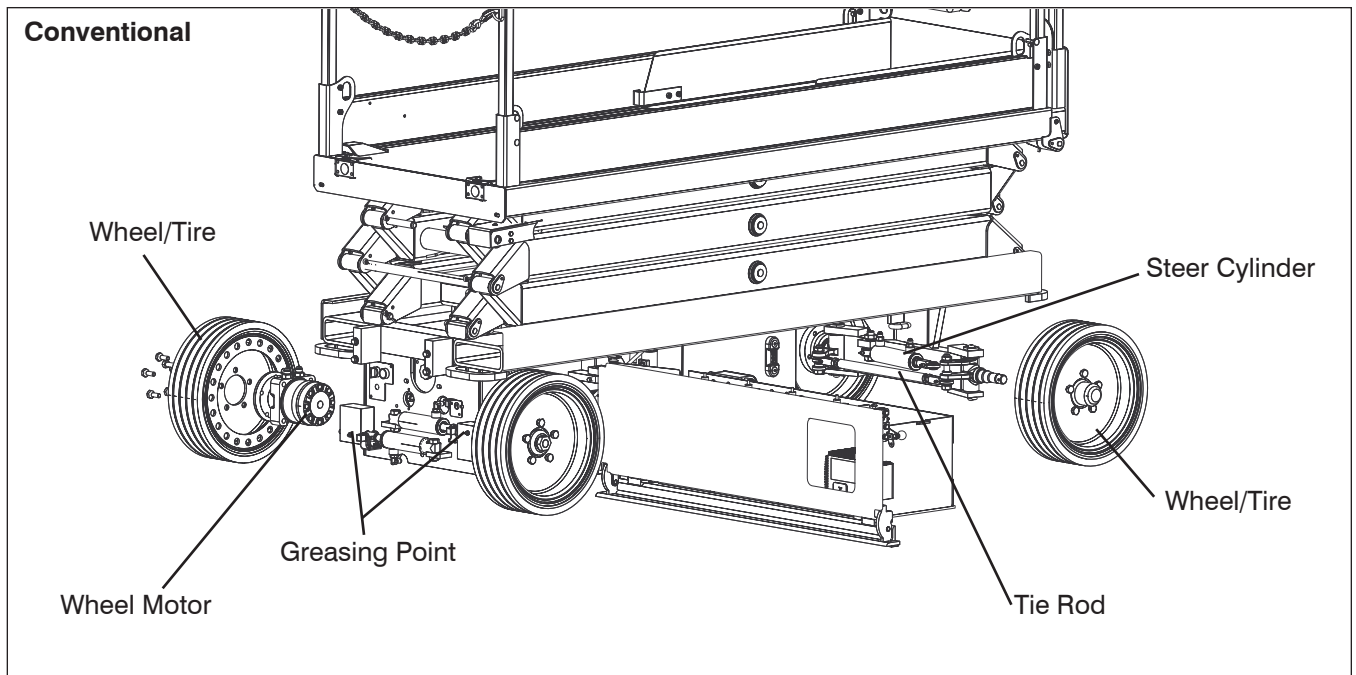

- **Steer Cylinder Assembly**
 - Ensure steer cylinder assembly is properly secured and there are no loose or missing parts.
 - **Wheel/Tire Assembly**

The aerial platform is either equipped with solid rubber tires or foam-filled tires. Tire and/or wheel failure could result in an aerial platform tip-over. Component damage may also result if problems are not discovered and repaired in a timely fashion.

 - Check all tire treads and sidewalls for cuts, cracks, punctures and unusual wear.
 - Check each wheel for damage and cracked welds.
 - Check each lug nut for proper torque to ensure none are loose.
 - Check wheel motor assembly for loose or missing parts and signs of visible damage.
 - Ensure wheels are aligned and true vertically and horizontally.
 - **Tie Rod (Conventionals)**
 - Ensure there are no loose or missing parts, tie rod end studs are locked and there is no visible damage.
 - **Greasing Points**
 - Ensure greasing points have no sign of visible damage and are free from dirt and obstructions.
- B - Frequent Inspection**
- Locate grease fittings and pump grease as needed.

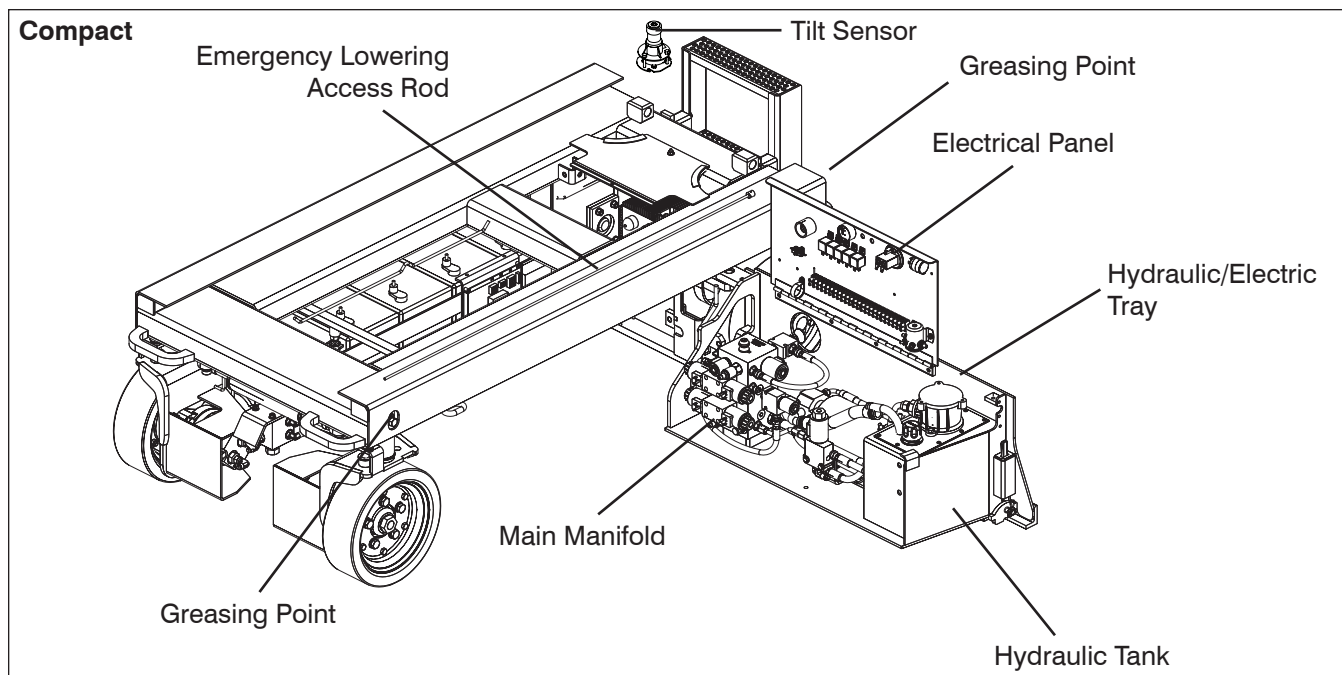

1.1-5 Hydraulic/Electric Tray Side

- Ensure tray latch is secure and in proper working order.
- **Pothole Protection Device**
 - Ensure mechanisms have no sign of visible damage and are free from dirt and obstructions.
- **Hydraulic Tank**
 - Ensure hydraulic filler cap is secure.
 - Ensure tank shows no visible damage and no evidence of hydraulic leakage.
- **Hydraulic Oil**
 - Ensure platform is fully lowered, and then visually inspect the sight gauge located on the side of the hydraulic oil tank.
 - The hydraulic oil level should be at or slightly above the top mark of the sight glass.
- **C - Annual Inspection**
 - For hydraulic oil replacement procedure, refer to [section 5](#).
- **Hydraulic Pump and Motor**
 - Ensure there are no loose or missing parts and there is no visible damage.
- **Electrical Panel**
 - Ensure panel is properly secured and there is no visible damage.
 - Ensure there are no loose wires or missing fasteners.
- **Proportional and Main Manifolds**
 - Ensure all fittings and hoses are properly tightened and there is no evidence of hydraulic leakage.
 - Ensure there are no loose wires or missing fasteners.
- **Tilt Sensor (If Equipped)**
 - Ensure tilt sensor is properly secured and there is no visible damage.
- **Load/Tilt Sensor - CE**
 - Ensure load/tilt sensor is properly secured and there is no visible damage.
- **Emergency Lowering Access Rod (If Equipped)**
 - Ensure rod is properly secured and there is no visible damage.

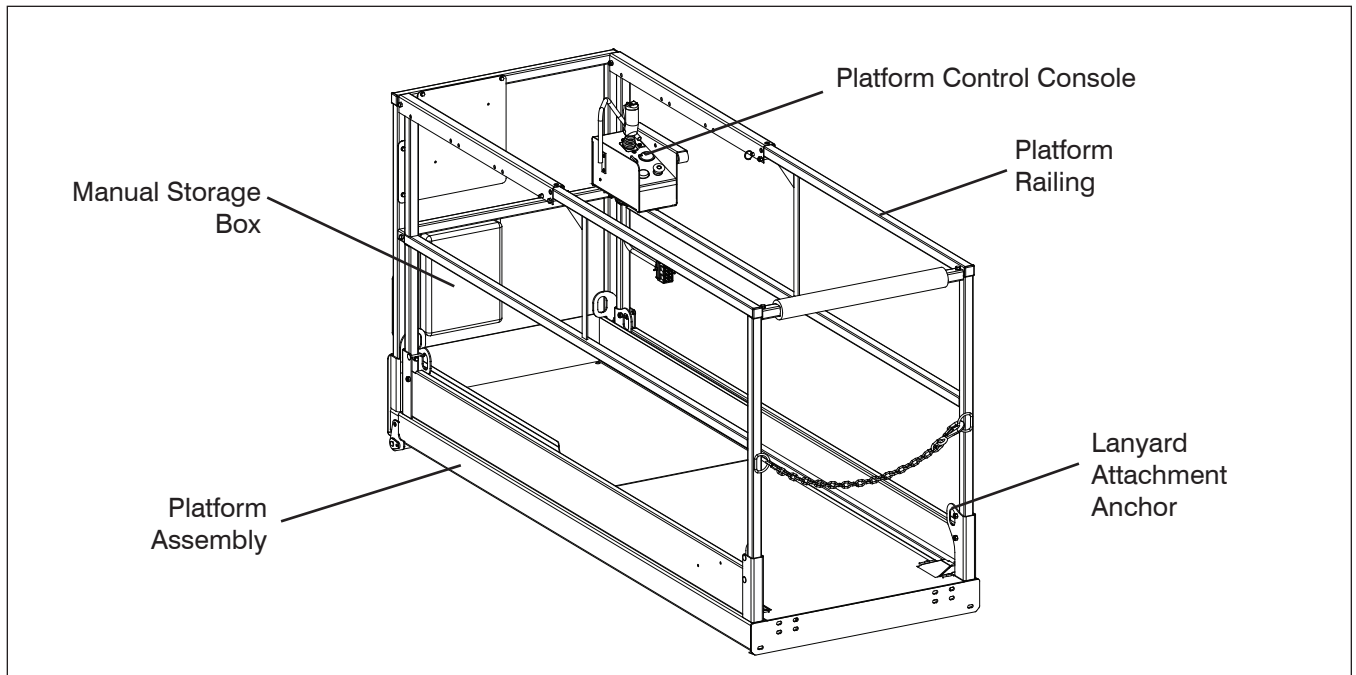

1.1-6 Platform Assembly



WARNING

Ensure that you maintain three points of contact to mount/dismount platform.

1. Use the ladder of aerial platform to access platform.
 2. Close the gate.
 - Ensure there are no loose or missing parts and there is no visible damage.
 - Ensure all fasteners are securely in place.
 - Ensure all railings are properly positioned and secured.
 - Ensure gate is in good working order.
- **Lanyard Attachment Anchors**
 - Ensure attachment rings are secure and no visible damage.
 - **AC Outlet on Platform**
 - Ensure outlet has no visible damage and free from dirt or obstructions.
 - **Platform Control Console**
 - Ensure all switches and controller are returned to neutral and are properly secured.
 - Ensure there are no loose or missing parts and there is no visible damage.
 - **Manuals**

Ensure a copy of operating manual and other important documents are enclosed in manual storage box.

 - Check to be sure manual storage box is present and in good condition.
 - Ensure manuals are legible and in good condition.
 - Always return manuals to the manual storage box after use.

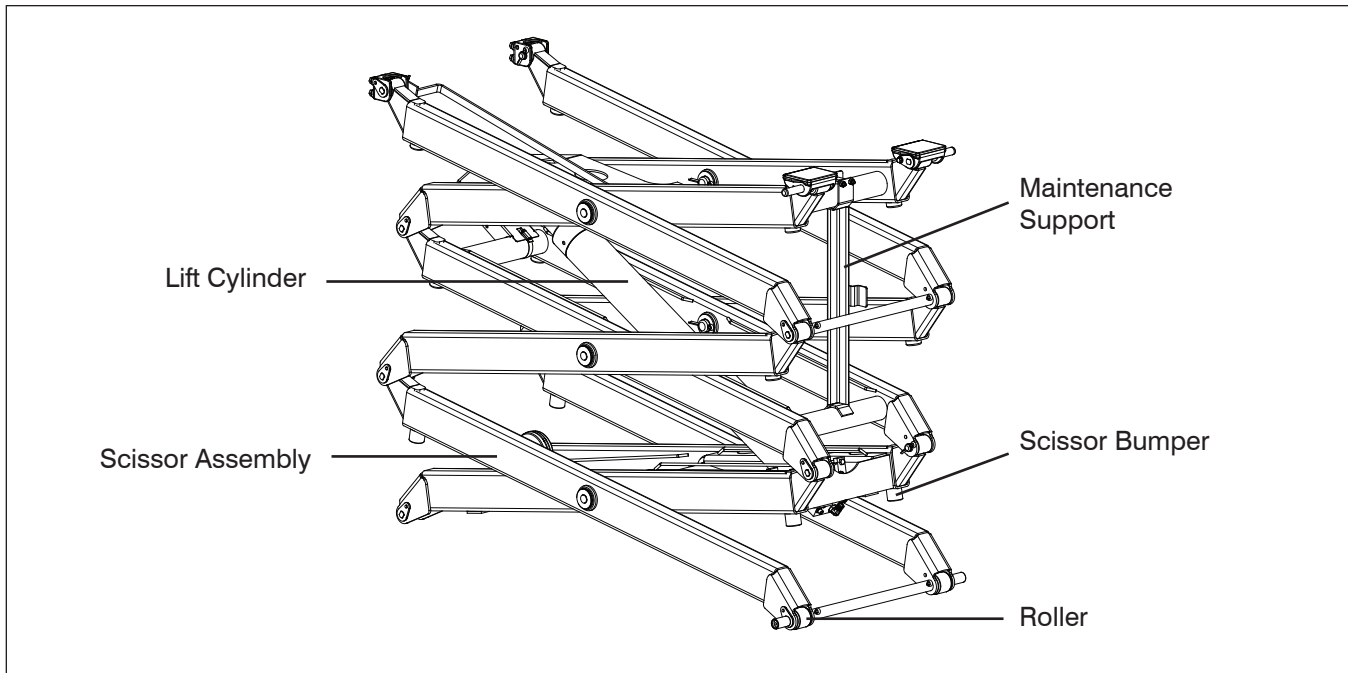

- **Powered Extension Control Console (If Equipped)**
 - Ensure all switches are returned to neutral and are properly secured.
 - Ensure there are no loose or missing parts and there is no visible damage.



WARNING

Ensure that you maintain three points of contact to mount/dismount platform.

- **Scissor Bumpers**
 - Ensure bumpers are secure and shows no sign of visible damage.
- **Rollers**
 - Ensure rollers are secure and there is no visible damage.
 - Ensure rollers' path of travel are free from dirt and obstructions.
- **Lift Cylinder(s)**
 - Ensure each lift cylinder is properly secured, there are no loose or missing parts and there is no evidence of damage.
 - Ensure all fittings and hoses are properly tightened and there is no evidence of hydraulic leakage.

3. Use the ladder to dismount from platform.

1.1-7 Lifting Mechanism

1. Raise the platform until there is adequate clearance to swing down the maintenance support.
 - **Maintenance Support**
 - Ensure maintenance support is properly secured and shows no visible damage.
 - **Scissor Assembly**
 - Ensure scissor assembly shows no visible damage and no signs of deformation in weldments.
 - Ensure all pins are properly secured.
 - Ensure cables and wires are properly routed and shows no signs of wear and/or physical damage.

2. Raise the platform until there is adequate clearance to swing up the maintenance support.
3. Swing up maintenance support into storage bracket.
4. Fully lower the platform.

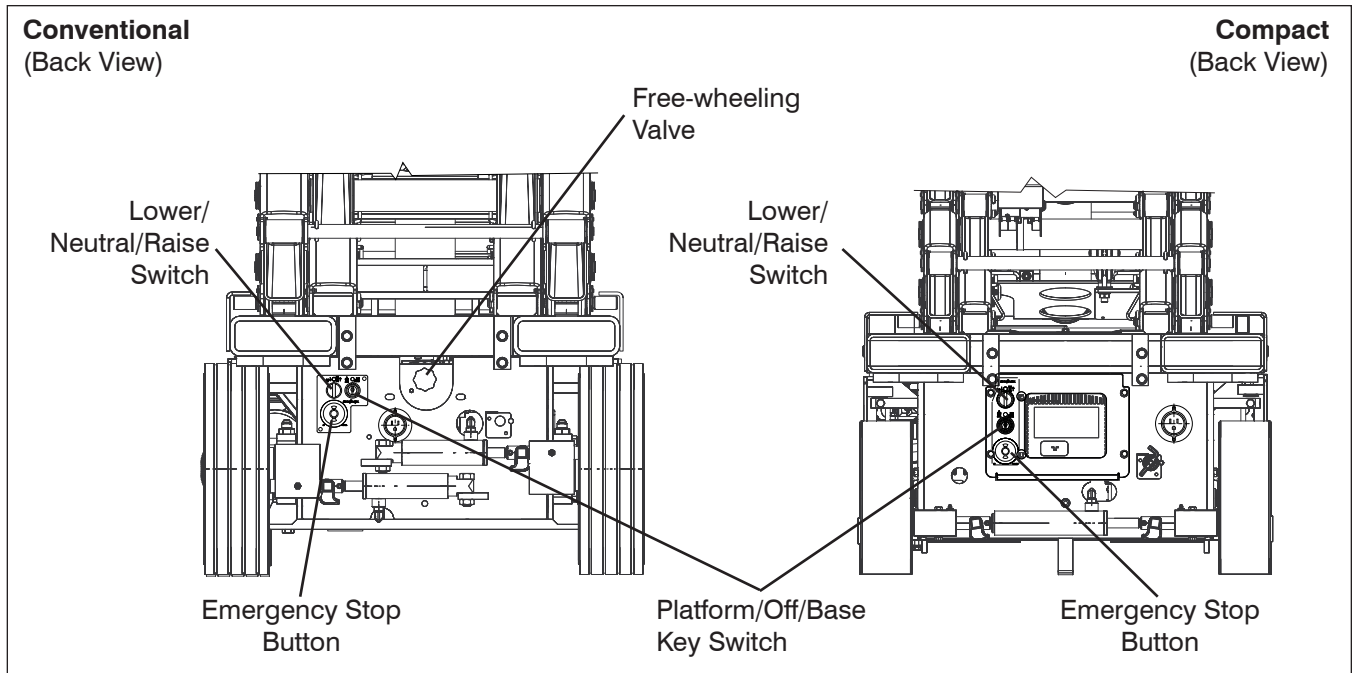

1.2 Function Tests

Function tests are designed to discover any malfunctions before aerial platform is put into service. The operator must understand and follow step-by-step instructions to test all aerial platform functions.



WARNING

Never use a malfunctioning aerial platform. If malfunctions are discovered, aerial platform must be tagged and placed out of service. Repairs to aerial platform may only be made by a qualified service technician.

After repairs are completed, operator must perform a pre-operation inspection and a series of function tests again before putting aerial platform into service.

Prior to performing function tests, be sure to read and understand [Section 2.10](#) - Start Operation of the operating manual.

1.2-1 Test Main Power Disconnect Switch

1. At rear of the base, turn main power disconnect switch to “○” off position.
Result: Aerial platform functions should not operate.

1.2-2 Base Control Console





WARNING

Ensure that you maintain three points of contact when using the ladder to mount/dismount platform.

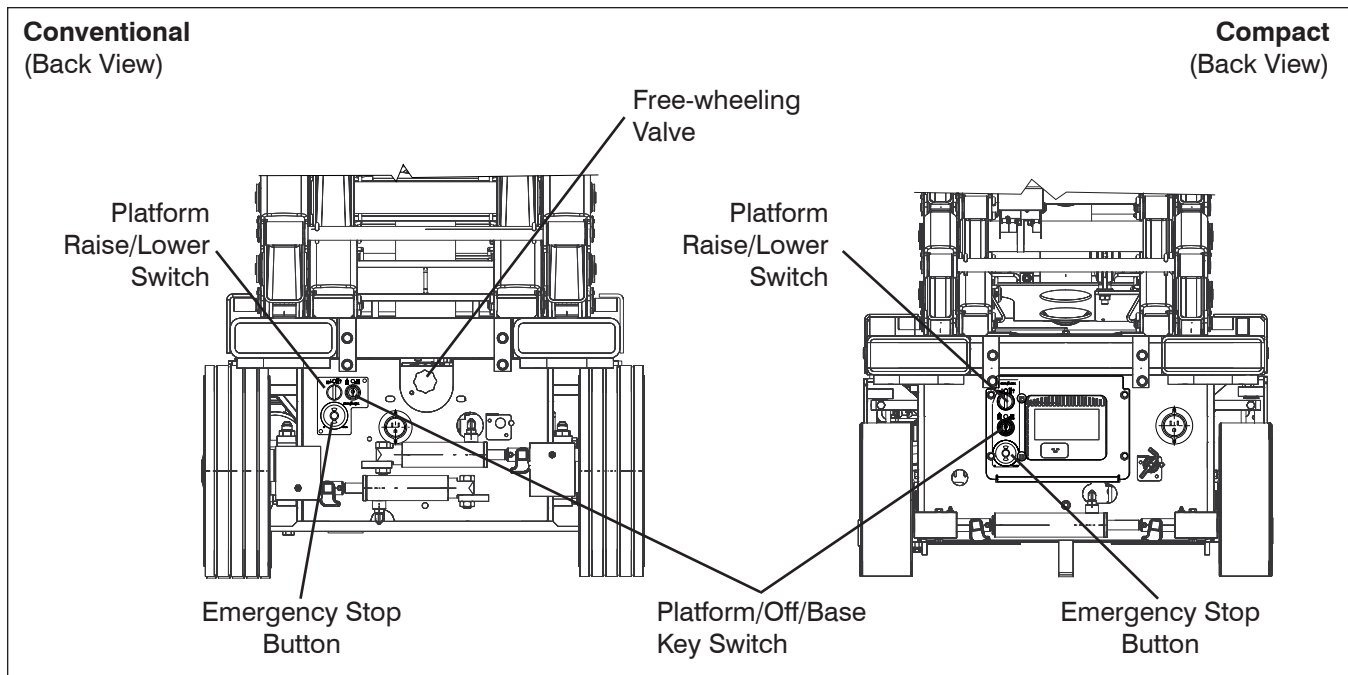
1. Use the ladder of aerial platform to access platform.
2. Close the gate.
3. On platform control console, pull out “○” emergency stop button.
4. Use the ladder to dismount from platform.
5. Turn main power disconnect switch to “|” on position.





• **Test Base Emergency Stop**

1. Push in “” emergency stop button and attempt to raise or lower the platform.
Result: Platform raising and lowering functions should not operate.
2. Pull out base “” emergency stop button.

• **Test Off/Platform/Base Switch**







Be aware of overhead obstructions or other possible hazards around the aerial platform when lifting.

1. Select off/platform/base key switch “” off position. Attempt to raise or lower the platform.
Result: Platform raising and lowering functions should not operate.
2. Select off/platform/base key switch to “” platform position. Attempt to raise or lower the platform.
Result: Platform raising and lowering functions should not operate.

3. Select and hold off/platform/base key switch to “” base position. Attempt to raise or lower the platform.
Result: Platform raising and lowering functions should operate.

• **Test Lower/Neutral/Raise Switch**

1. Select and hold off/platform/base key switch to “” base position and “” raise the platform with lower/neutral/raise switch.
Result: Platform should rise.
2. Select and hold off/platform/base key switch to “” base position and “” lower the platform with lower/neutral/raise switch.
Result: Platform should lower.

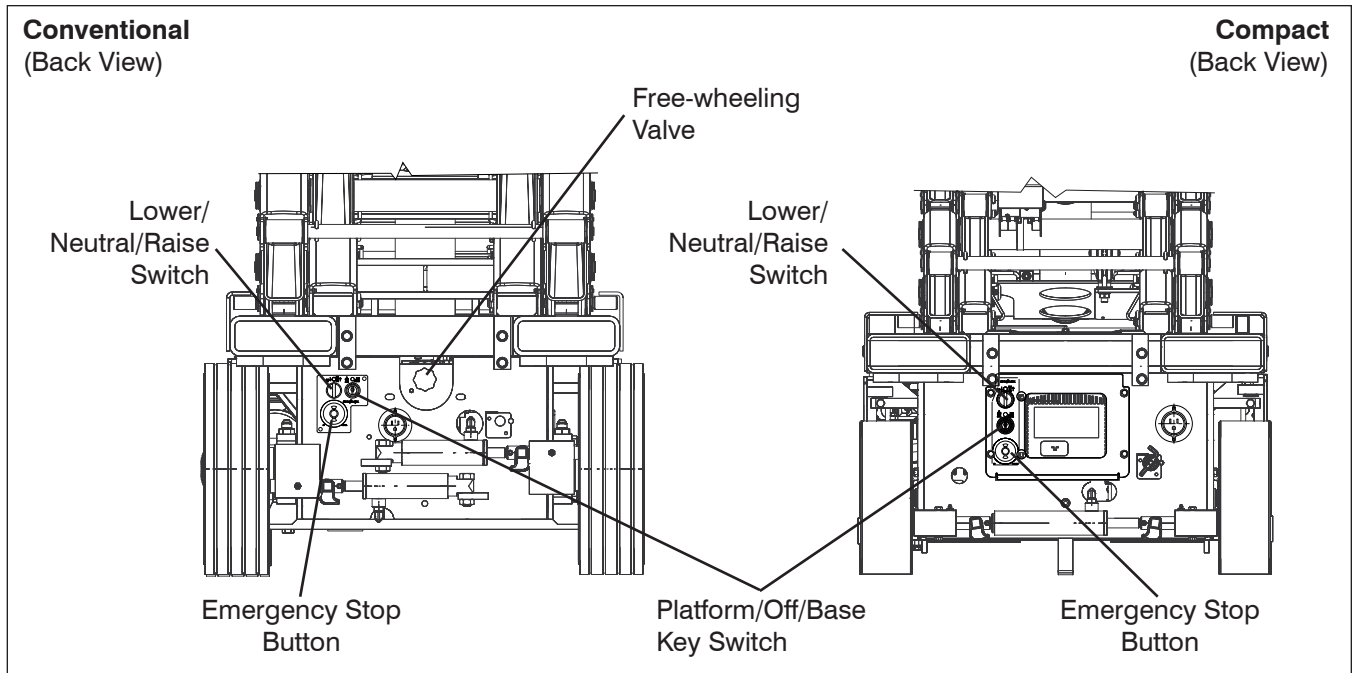

- **Test Emergency Lowering**



1. Raise the platform.
2. Locate holding valve manual override knob at the base of each lift cylinder. Depress and turn counterclockwise. If necessary, use access rod that is located on the base of the aerial platform.
3. On hydraulic/electric tray, pull out and hold emergency lowering valve to fully lower the platform.
Result: The platform should lower.
4. To restore normal operation, depress and turn holding valve manual override knobs clockwise.

- **Test Free-wheeling**

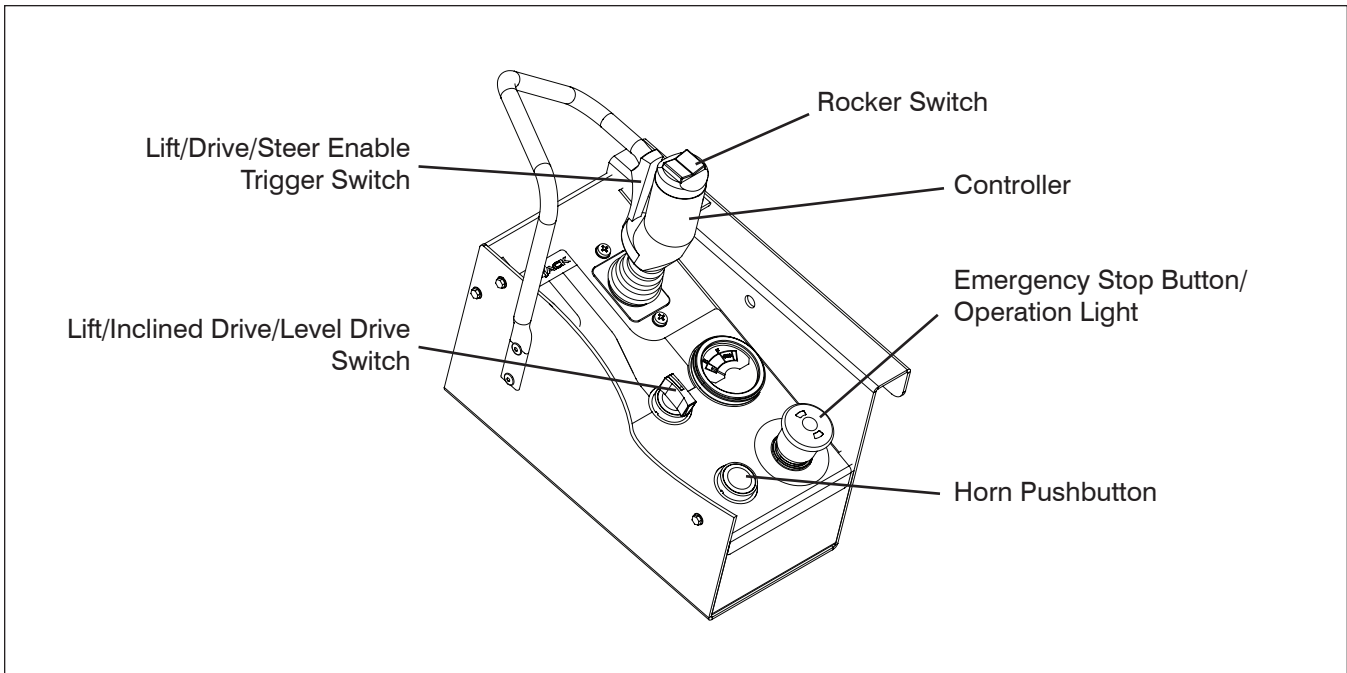
1. Ensure path of intended motion is clear.
2. Release the brake manually.
3. Turn free-wheeling valve knob counterclockwise to a fully opened position and attempt to push/pull the aerial platform.
Result: Platform should move.
4. Turn free-wheeling valve knob clockwise to a fully closed position for normal operation.
5. Reengage the brake.



1.2-3 Platform Control Console

1. Ensure base “” emergency stop button is pulled out.
2. Select off/platform/base key switch to “” platform position.
3. Ensure main power disconnect switch is in “” on position.



WARNING

Ensure that you maintain three points of contact when using the ladder to mount/dismount platform.

4. Use the ladder of aerial platform to access platform.
5. Close the gate.
6. On platform control console, pull out “” emergency stop button.

• **Test Platform Emergency Stop**

1. Push in “” emergency stop button and attempt to activate any platform function.
Result: All selected platform functions should not operate.





• **Test Enable Trigger Switch**

1. Without activating “” enable trigger switch, attempt to activate any platform function.
Result: All platform functions should not operate.

• **Test Steering**



NOTE

Inclined drive (low speed/high torque) is not available on 3215 and 3219 models.

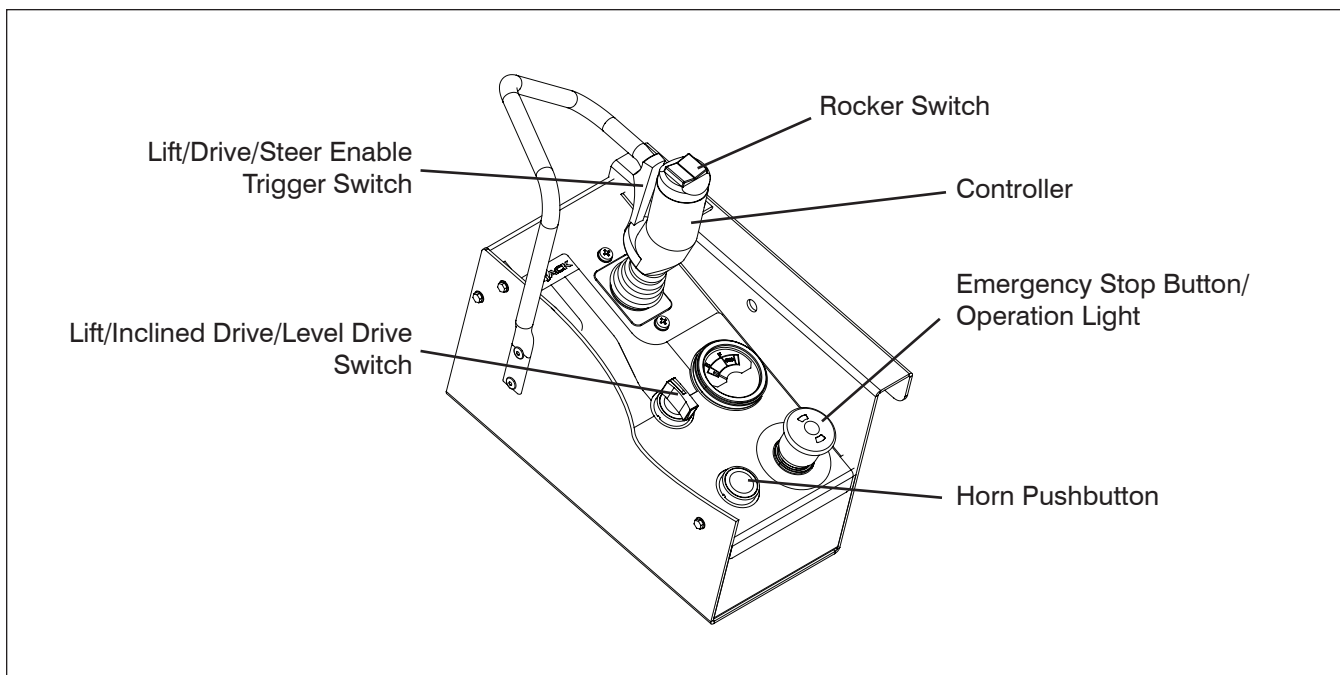
1. Select lift/inclined drive/level drive switch to either “” inclined drive (low speed/high torque) or “” level drive (high speed/low torque) position.
2. Activate and hold “” enable trigger switch.
3. Press rocker switch on top of controller handle to “” left and “” right.
Result: Steer wheels should turn left and right.



• Test Driving







1. Ensure path of intended motion is clear.
2. Activate and hold “” enable trigger switch.
3. Slowly move controller handle in “” forward direction until aerial platform begins to move, and then return handle to center position.
Result: Aerial platform should move in forward direction, and then come to a stop.
4. Slowly move controller handle in “” reverse direction until aerial platform begins to move, and then return handle to center position.
Result: Aerial platform should move in reverse direction, and then come to a stop.

• Test Brakes



WARNING

Brakes will engage instantly when you release the controller handle, causing aerial platform to stop immediately.

1. Ensure path of intended motion is clear.
2. Activate and hold “” enable trigger switch.
3. Drive aerial platform “” forward and then “” backward. Test brake by releasing controller handle.
Result: Aerial platform should come to a stop. If aerial platform pulls to one side while stopping, do not operate aerial platform until brake adjustments have been checked.
4. Drive aerial platform “” forward and then “” backward. Test brake again by releasing “” enable trigger switch only.
Result: Aerial platform should come to an instant and abrupt stop. If aerial platform does not stop immediately, or if aerial platform pulls to one side while stopping, do not operate aerial platform until brake adjustments have been checked.

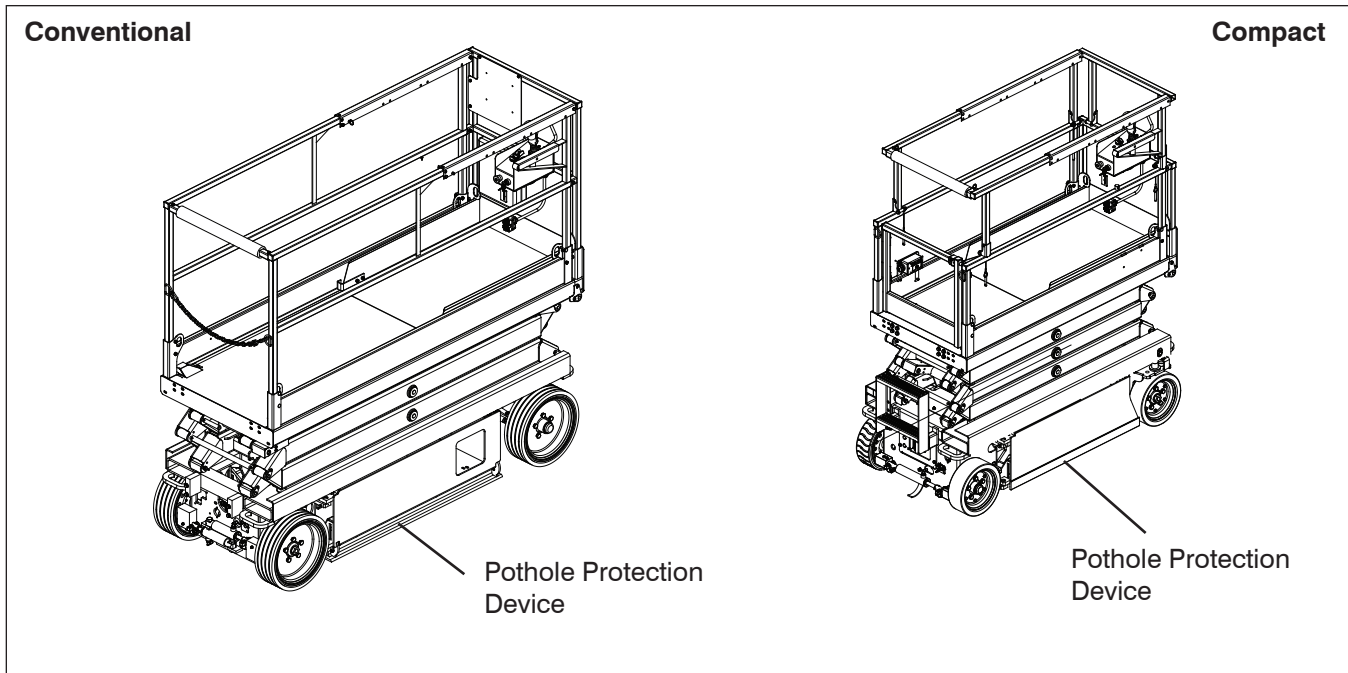



• **Test Platform Raising/Lowering**



WARNING

Be aware of overhead obstructions or other possible hazards around the aerial platform when lifting.

1. Select lift/torque/drive switch to “” lift position.
2. Activate and hold “” enable trigger switch.
3. Push controller handle and raise the platform to an approximate height of 1 ft. (30.5 cm).
Result: Platform should rise.
4. Pull controller handle and lower the platform fully.
Result: Platform should lower.

• **Test Lowering Warning - CE**

1. Raise the platform until approximately a height of 3 to 4 meters is reached then attempt to fully lower the platform.
Result: Platform should stop lowering at a height of 2.5 meters high and an alarm should sound.

2. Release controller handle.

• **Test Horn**

1. Push “” horn pushbutton.
Result: Horn should sound.

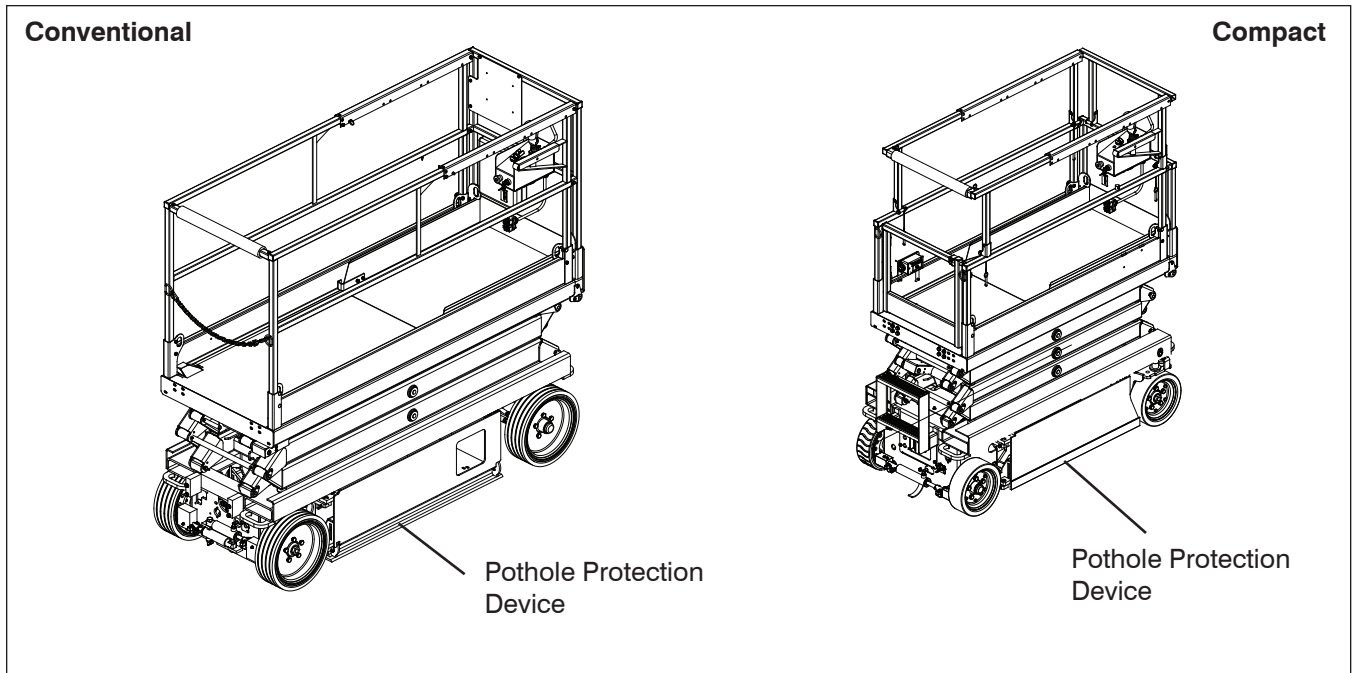

- **Test Pothole Sensor**

**WARNING**

Ensure that you maintain three points of contact to mount/dismount platform.

1. Use the ladder to dismount from platform and place a block, approximately 1.5" (3.75 cm), under the hydraulic/electric tray.
2. Use the ladder of aerial platform to access platform.
3. Close the gate.
4. Raise the platform until approximately a height of 7 feet (2 meters) is reached and attempt to drive forward or reverse.
Result: Aerial platform should not move forward or backward.
5. Repeat the steps above with block placed under battery tray.
Result: Aerial platform should not move forward or backward.

- **Test Speed Limit**

**WARNING**

Be aware of overhead obstructions or other possible hazards around the aerial platform when lifting.

1. Ensure path of intended motion is clear.
2. Raise the platform until approximately a height of 7 feet (2 meters) is reached and attempt to drive forward or reverse.
Result: Aerial platform should move slower than when it was in stowed position.

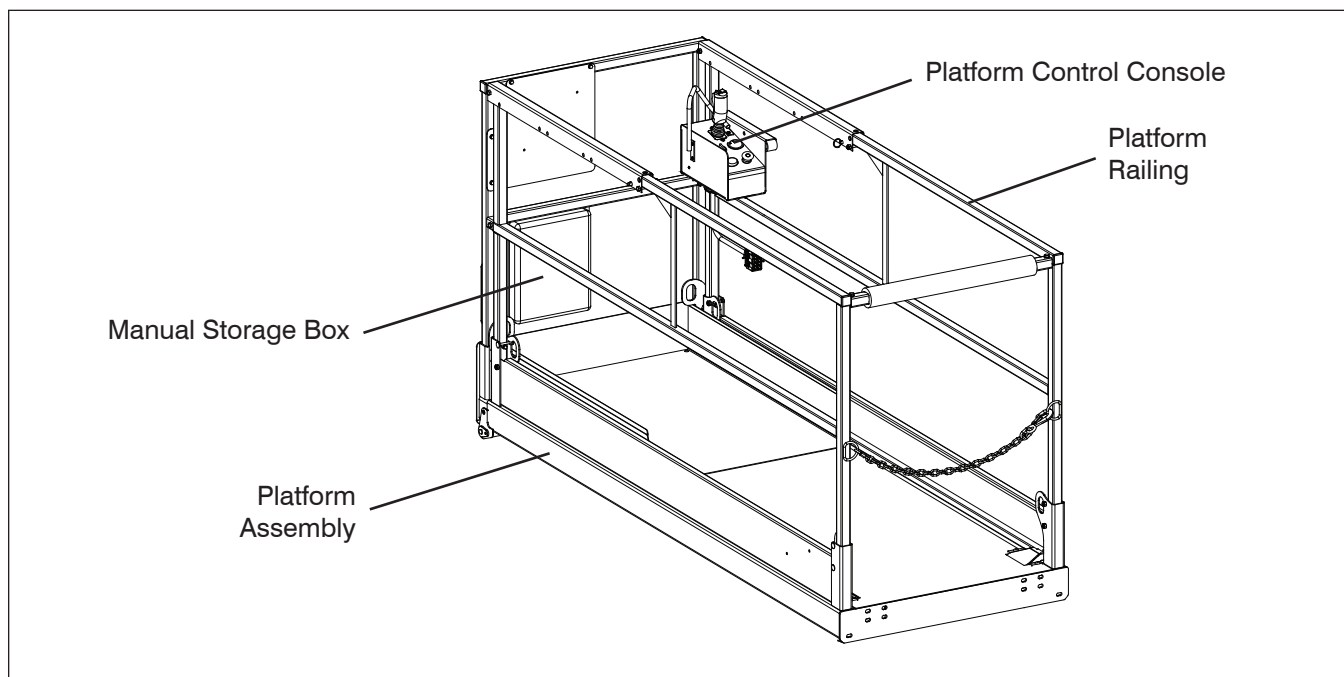

- **Test Tilt Sensor (If Equipped)**

**WARNING**

Be aware of overhead obstructions or other possible hazards around the aerial platform when lifting.

**WARNING**

Ensure that there are no personnel or obstructions in the path of travel, including blind spots.

1. Move the aerial platform on to a slope not greater than 4.5°.
2. Use the ladder to dismount from platform.
3. On base control console, slowly raise the platform.
Result: When platform reaches an appropriate height, a warning signal should sound and platform stop raising as lift and drive controls should be disabled.

Section 2 MAINTENANCE TABLES AND DIAGRAMS

Table of Contents

Tables

2.1a	Specifications and Features (ANSI/CSA).....	2
2.1b	Specifications and Features (CE)	4
2.1c	Specifications and Features (AS).....	6
2.2a	Floor Loading Pressure (ANSI/CSA).....	9
2.2b	Floor Loading Pressure (CE)	10
2.2c	Floor Loading Pressure (AS).....	11
2.3a	Maximum Platform Capacities (Evenly Distributed) (ANSI/CSA)	12
2.3b	Maximum Platform Capacities (Evenly Distributed) (CE)	13
2.3c	Maximum Platform Capacities (Evenly Distributed) (AS)	14
2.4	Torque Specifications	15

Table 2.1a Specifications and Features (ANSI/CSA)

MODEL	3215	3219	3220	3226
Weight *	2400 lb. 1089 kg	2580 lb. 1170 kg	3400 lb. 1542 kg	4180 lb. 1896 kg
Width	32" 0.81 m		32" 0.81 m	
Length	70.0" 1.78 m		91" 2.3 m	
Platform Size	26" x 64" 0.66 m x 1.63 m		28" x 83" 0.71 x 2.1 m	
Height				
Working Height	21' 6.4 m	25' 7.6 m	26' 8.1 m	32' 9.9 m
Platform Elevated Height	15' 4.6 m	19' 5.8 m	20' 6.1 m	26' 7.9 m
Stowed Platform Height	34.5" 0.88 m	39" 0.99 m	38" 0.97 m	45" 1.1 m
Stowed Height Railings Up	74" 1.88 m	78.5" 1.99 m	82" 2.1 m	89" 2.3 m
Drive Height (All Standards)	FULL			
Standard Operating Time				
Lift Time (No Load)	18 sec.	20 sec.	27 sec.	47 sec.
Lower Time (No Load)	32 sec.	39 sec.	41 sec.	63 sec.
Lift Time (Rated Load)	23 sec.	25 sec.	33 sec.	51 sec.
Lower Time (Rated Load)	24 sec.	29 sec.	29 sec.	46 sec.
Chassis				
Normal Drive Speed	2 mph 3.2 km/h		1.9 mph 3.0 km/h	2.4 mph 3.8 km/h
Elevated Drive Speed	0.65 mph 1.05 km/h		0.64 mph 1.0 km/h	0.64 mph 1.0 km/h
High Torque Drive Speed	N/A		0.95 mph 1.5 km/h	1.2 mph 1.9 km/h
Gradeability	23%		25%	
Tires	12 x 4 x 8 Solid Rubber		16 x 5 x 12 Solid Rubber	

60156AK-ANSI-1-R

* Weight with standard 3' (0.9 m) or 4' (1.2 m) extension platform.
Refer to nameplate for aerial platforms with 5' (1.5 m) or 6' (1.8 m) extension platform.

Table 2.1a Specifications and Features (ANSI/CSA) (Continued)

MODEL	4620	4626	4632	6826	6832
Weight *	4100 lb. 1860 kg	4700 lb. 2132 kg	5075 lb. 2302 kg	5380 lb. 2440 kg	5680 lb. 2576 kg
Width	46" 1.17 m			68" 1.73 m	
Length	91" 2.31 m			99.5" 2.52 m	
Platform Size	42" x 84" 1.07 m x 2.13 m			57" x 84" 1.45 m x 2.13 m	
Height					
Working Height	26' 7.92 m	32' 9.75 m	38' 11.6 m	32' 9.75 m	38' 11.6 m
Platform Elevated Height	20' 6.1 m	26' 7.9 m	32' 9.8 m	26' 7.9 m	32' 9.8 m
Stowed Platform Height	38" 0.97 m	45" 1.14 m	48.5" 1.23 m	50" 1.27 m	55.5" 1.40 m
Stowed Height Railings Up	77.25" 1.96 m	84.5" 2.15 m	88" 2.24 m	93.6" 2.38 m	99" 2.51 m
Drive Height	20' 6.1 m	26' 7.9 m	32' 9.8 m	26' 7.9 m	32' 9.7 m
Standard Operating Time					
Lift Time (No Load)	24 sec.	48 sec.	50 sec.	N/A	58 sec.
Lower Time (No Load)	48 sec.	45 sec.	62 sec.	N/A	63 sec.
Lift Time (Rated Load)	32 sec.	54 sec.	59 sec.	65 sec.	60 sec.
Lower Time (Rated Load)	32 sec.	32 sec.	49 sec.	57 sec.	51 sec.
Chassis					
Normal Drive Speed	2.0 mph 3.2 km/h				
Elevated Drive Speed	0.56 mph 0.90 km/h				0.46 mph 0.74 km/h
High Torque Drive Speed	1.0 mph 1.6 km/h				
Gradeability	25%				
Tires	16 x 5 x 12 Solid Rubber			23 x 10.5 x 12 Foam Filled ¹	

60156AK-ANSI-2-R

- * Weight with standard 3' (0.9 m) or 4' (1.2 m) extension platform.
Refer to nameplate for machines with 5' (1.5 m) or 6' (1.8 m) extension platform.
- ¹ Fill hardness: 55 Durometer

Table 2.1b Specifications and Features (CE)

MODEL	3215	3219	3220	3226
Weight *	1090 kg	1170 kg	1542 kg	1896 kg
Width	0.81 m		0.81 m	
Length	1.78 m		2.3 m	
Platform Size	0.66 x 1.63 m		0.71 x 2.1 m	
Height				
Working Height	6.4 m	7.6 m	8.1 m	9.9 m
Platform Elevated Height	4.6 m	5.8 m	6.1 m	7.9 m
Stowed Platform Height	0.88 m	0.99 m	0.97 m	1.1 m
Stowed Height Railings Up	1.88 m	1.99 m	2.1 m	2.3 m
Drive Height (All Standards)	FULL			
Standard Operating Time				
Lift Time (No Load)	18 sec.	20 sec.	27 sec.	47 sec.
Lower Time (No Load)	32 sec.	39 sec.	41 sec.	63 sec.
Lift Time (Rated Load)	23 sec.	25 sec.	33 sec.	51 sec.
Lower Time (Rated Load)	24 sec.	29 sec.	29 sec.	46 sec.
Chassis				
Normal Drive Speed	3.2 km/h		3.0 km/h	3.8 km/h
Elevated Drive Speed	1.05 km/h		1.0 km/h	1.0 km/h
High Torque Drive Speed	N/A		1.5 km/h	1.9 km/h
Gradeability	23%		25%	
Tires (Solid Rubber)	12 x 4 x 8		16 x 5 x 12	

60156AL-CE-1-R

* Weight with standard 0.9 m extension platform.
(Refer to nameplate for aerial platforms with 1.5 m or 1.8 m extension platform.)

Table 2.1b Specifications and Features (CE) (Continued)

MODEL	4620	4626	4632	6826	6832
Weight †	1860 kg	2130 kg	2300 kg	2440 kg	2700 kg
Width	1.17 m			1.73 m	
Length	2.31 m			2.52 m	
Platform Size	1.07 x 2.11 m			1.53 x 2.05 m	
Height					
Working Height	7.92 m	9.75 m	11.6 m	9.75 m	11.6 m
Platform Elevated Height	6.1 m	7.9 m	9.7 m	7.9 m	9.7 m
Stowed Platform Height	0.97 m	1.14 m	1.23 m	1.27 m	1.40 m
Stowed Height Railings Up	1.96 m	2.15 m	2.24 m	2.37 m	2.51 m
Drive Height	6.1 m	7.9 m	9.7 m	7.0 m	7.9 m
Standard Operating Time					
Lift Time (No Load)	24 sec.	48 sec.	50 sec.	N/A	58 sec.
Lower Time (No Load)	48 sec.	45 sec.	62 sec.	N/A	63 sec.
Lift Time (Rated Load)	32 sec.	54 sec.	59 sec.	65 sec.	60 sec.
Lower Time (Rated Load)	32 sec.	32 sec.	49 sec.	57 sec.	51 sec.
Chassis					
Normal Drive Speed	3.2 km/h				
Elevated Drive Speed	0.90 km/h				0.74 km/h
High Torque Drive Speed	1.6 km/h				
Gradeability	25%				
Tires	16 x 5 x 12 Solid Rubber			23 x 10.5 x 12 Foam Filled ¹	

60156AL-CE-2-R

† Weight with standard 0.9m extension platform. Refer to serial nameplate for specific applications.

¹ Fill hardness: 55 Durometer

Table 2.1c Specifications and Features (AS)

MODEL	3215	3219	3220	3226
Weight *	1090 kg	1170 kg	1583 kg	1864 kg
Width	0.81 m		0.84 m	
Length	1.78 m		2.32 m	
Platform Size	0.66 x 1.57 m		0.71 x 2.13 m	
Height				
Stowed Platform Height	0.88 m	0.99 m	0.97 m	1.15 m
Platform Elevated Height	4.6 m	5.8 m	6.1 m	7.9 m
Working Height	6.4 m	7.6 m	7.92 m	9.75 m
Stowed Height Railings Up	1.88 m	1.99 m	2.02 m	2.2 m
Drive Height (All Standards)	FULL			
Standard Operating Time				
Lift Time (No Load)	18 sec.	20 sec.	27 sec.	43 sec.
Lower Time (No Load)	32 sec.	39 sec.	41 sec.	52 sec.
Lift Time (Rated Load)	23 sec.	25 sec.	33 sec.	56 sec.
Lower Time (Rated Load)	24 sec.	29 sec.	29 sec.	42 sec.
Chassis				
High Travel Speed	3.2 km/h			3.9 km/h
Elevated Drive Speed	1.05 km/h		1 km/h	1.1 km/h
High Torque Drive Speed	N/A		1.9 km/h	2.14 km/h
Gradeability	23%		25%	
Tires (Solid Rubber)	12 x 4 x 8		16 x 5 x 12	

60156AJ-AS-1

- * Weight with standard 0.9 m or 1.2 m extension platform.
Refer to nameplate for aerial platforms with 1.5 m or 1.8 m extension platform.

Table 2.1c Specifications and Features (AS) (Continued)

MODEL	4620	4626	4632	6826	6832
Weight †	1860 kg	2130 kg	2300 kg	2440 kg	2700 kg
Width	1.17 m			1.73 m	
Length	2.31 m			2.52 m	
Platform Size	1.07 x 2.11 m			1.53 x 2.05 m	
Height					
Working	7.92 m	9.75 m	11.6 m	9.75 m	11.6 m
Platform Elevated	6.1 m	7.9 m	9.7 m	7.9 m	9.7 m
Fixed Railing	1.96 m	2.15 m	2.24 m	2.37 m	2.51 m
Platform Lowered	0.97 m	1.14 m	1.23 m	1.27 m	1.40 m
Drive Height	6.1 m	7.9 m	9.7 m	7.0 m	7.9 m
Standard Operating Time					
Lift Time (No Load)	24 sec.	48 sec.	50 sec.	N/A	58 sec.
Lower Time (No Load)	48 sec.	45 sec.	62 sec.	N/A	63 sec.
Lift Time (Rated Load)	32 sec.	54 sec.	59 sec.	65 sec.	60 sec.
Lower Time (Rated Load)	32 sec.	32 sec.	49 sec.	57 sec.	51 sec.
Chassis					
High Travel Speed	3.2 km/h				
Elevated Drive Speed	0.90 km/h				0.64 km/h
High Torque Drive Speed	1.6 km/h				
Gradeability	25%				
Tires	16 x 5 x 12 Solid Rubber			23 x 10.5 x 12 Foam Filled ¹	

60156AJ-AS-2

† Weight with standard 0.9m extension platform. Refer to serial nameplate for specific applications.

¹ Fill hardness: 55 Durometer

Floor Loading Pressure

Locally Concentrated Pressure (LCP):

Foot Print Area = Tread Contact Area

$$LCP = \frac{\text{Aerial Platform Weight} + \text{Capacity}}{\text{Foot Print Area} \times 4 \text{ (Tires)}}$$

Overall Uniform Pressure (OUP):

Base Area = Length x Width

$$OUP = \frac{\text{Aerial Platform Weight} + \text{Capacity}}{\text{Base Area}}$$

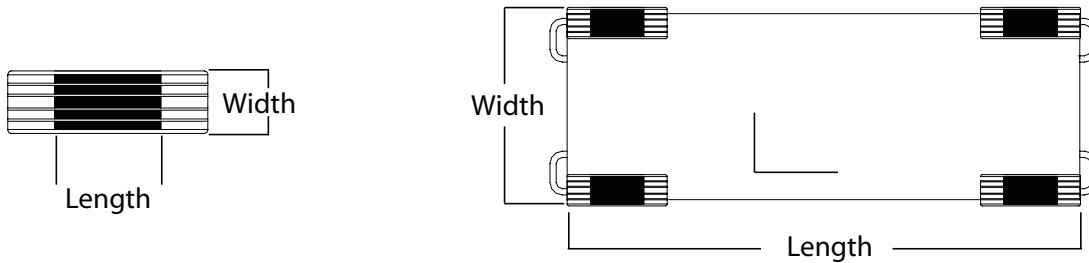
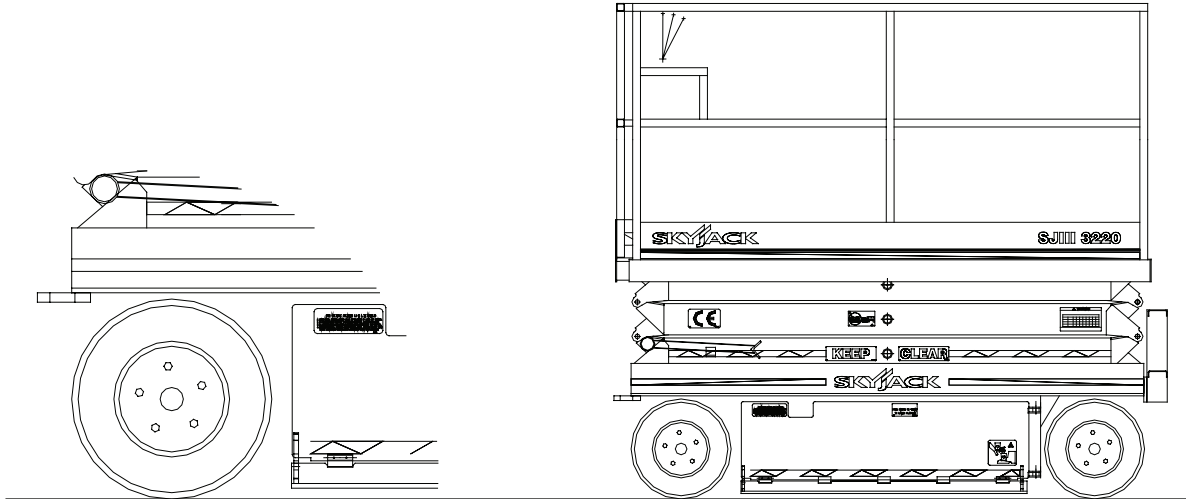

 **WARNING**

Intermixing tires of different types or using tires of types other than those originally supplied with this equipment can adversely affect stability. Therefore, replace tires only with the exact original Skyjack-approved type. Failure to operate with matched approved tires in good condition may result in death or serious injury.

Table 2.2a Floor Loading Pressure (ANSI/CSA)

MODEL		Total Aerial Platform Weight		Total Aerial Platform Load					
				Wheel		LCP**		OUP**	
		lb.	kg	lb.	kg	psi	KPa (kN/m ²)	psf	KPa (kN/m ²)
3215	min*	2400	1089	960	435	100	689.48	160	7.66
	max*	3000	1361	1200	544	110	758.42	200	9.58
3219	min*	2580	1170	1032	468	100	689.48	170	8.14
	max*	3130	1420	1252	568	110	758.42	210	10.05
3220	min*	3400	1542	1396	633	110	758.42	175	8.38
	max*	4299	1950	1936	878	130	896.32	245	11.73
3226	min*	4100	1860	1644	746	120	827.37	210	10.05
	max*	4610	2091	1844	836	130	896.32	235	11.25
4620	min*	4110	1864	1464	664	191	1316.90	146	6.99
	max*	5620	2549	1904	864	223	1537.53	199	9.53
4626	min*	4790	2173	1948	884	211	1454.79	171	8.19
	max*	5340	2422	2288	1038	235	1620.27	191	9.15
4632	min*	5068	2299	2112	958	208	1434.11	180	8.62
	max*	5768	2616	2392	1085	220	1516.85	204	9.77
6826	min*	5220	2368	2088	947	78	537.79	112	5.36
	max*	6420	2912	2568	1165	84	579.16	137	6.56
6832	min*	5870	2663	2348	1065	82	565.37	125	5.99
	max*	7070	3207	2829	1283	94	648.11	151	7.23

60354AD-ANSI

* **min** - Total aerial platform weight with no options

max - Aerial platform weight + all options + full capacity

** **LCP - Locally Concentrated Pressure** is a measure of how hard the aerial platform presses on the areas in direct contact with the floor. The floor covering (tile, carpet, etc.) must be able to withstand more than the indicated values above.

OUP - Overall Uniform Pressure is a measure of the average load the aerial platform imparts on the whole surface directly underneath it. The structure of the operating surface (beams, etc.) must be able to withstand more than the indicated values above.

NOTE:

The **LCP** or **OUP** that an individual surface can withstand varies from structure to structure and is generally determined by the engineer or architect for that particular structure.

Table 2.2b Floor Loading Pressure (CE)

MODEL		Total Aerial Platform Weight	Total Aerial Platform Load		
			Wheel	LCP**	OUP**
		kg	kg	KPa (kN/m ²)	KPa (kN/m ²)
3215	min*	1089	435	689.5	7.5
	max*	1361	544	758.5	9.5
3219	min*	1170	468	689.5	8.0
	max*	1420	568	758.5	10.0
3220	min*	1542	616	758.5	8.5
	max*	1950	780	896.5	11.5
3226	min*	1896	746	827.5	10.0
	max*	2091	836	896.5	11.5
4620	min*	1864	664	1317.0	7.0
	max*	2549	864	1537.5	9.5
4626	min*	2173	884	1455.0	8.0
	max*	2422	1038	1620.5	9.0
4632	min*	2299	958	1434.0	8.5
	max*	2616	1085	1517.0	10.0
6826	min*	2368	947	538.0	5.5
	max*	2912	1165	579.0	6.5
6832	min*	2663	1065	565.5	6.0
	max*	3207	1283	648.0	7.5

60354AF-CE-R

- * **min** - Total aerial platform weight with no options
max - Aerial platform weight + all options + full capacity
- ** **LCP - Locally Concentrated Pressure** is a measure of how hard the aerial platform presses on the areas in direct contact with the floor. The floor covering (tile, carpet, etc.) must be able to withstand more than the indicated values above.
OUP - Overall Uniform Pressure is a measure of the average load the aerial platform imparts on the whole surface directly underneath it. The structure of the operating surface (beams, etc.) must be able to withstand more than the indicated values above.

NOTE:

The **LCP** or **OUP** that an individual surface can withstand varies from structure to structure and is generally determined by the engineer or architect for that particular structure.

Table 2.2c Floor Loading Pressure (AS)

MODEL		Total Aerial Platform Weight		Total Aerial Platform Load					
				Wheel		LCP**		OUP**	
		kg	lb.	kg	lb.	KPa (kN/m ²)	psi	KPa (kN/m ²)	psf
3215	min*	1089	2400	435	960	689.48	100	7.66	160
	max*	1361	3000	544	1200	758.42	110	9.58	200
3219	min*	1170	2580	468	1032	689.48	100	8.14	170
	max*	1420	3130	568	1252	758.42	110	10.05	210
3220	min*	1583	3490	633	1396	758.42	110	8.38	175
	max*	2195	4840	878	1936	896.32	130	11.73	245
3226	min*	1860	4100	746	1644	827.37	120	10.05	210
	max*	2091	4610	836	1844	896.32	130	11.25	235
4620	min*	1864	4110	664	1464	1316.90	191	6.99	146
	max*	2549	5620	864	1904	1537.53	223	9.53	199
4626	min*	2173	4790	884	1948	1454.79	211	8.19	171
	max*	2422	5340	1038	2288	1620.27	235	9.15	191
4632	min*	2299	5068	958	2112	1434.11	208	8.60	180
	max*	2616	5768	1085	2392	1516.85	220	9.77	204
6826	min*	2368	5220	947	2088	537.79	78	5.38	112
	max*	2912	6420	1165	2568	579.16	84	6.55	137
6832	min*	2663	5870	1065	2348	565.37	82	6.00	125
	max*	3207	7070	1283	2829	648.11	94	7.24	151

60354AD-AS

* **min** - Total aerial platform weight with no options

max - Aerial platform weight + all options + full capacity

** **LCP - Locally Concentrated Pressure** is a measure of how hard the aerial platform presses on the areas in direct contact with the floor. The floor covering (tile, carpet, etc.) must be able to withstand more than the indicated values above.

OUP - Overall Uniform Pressure is a measure of the average load the aerial platform imparts on the whole surface directly underneath it. The structure of the operating surface (beams, etc.) must be able to withstand more than the indicated values above.

NOTE:

The **LCP** or **OUP** that an individual surface can withstand varies from structure to structure and is generally determined by the engineer or architect for that particular structure.

Table 2.3a Maximum Platform Capacities (Evenly Distributed) (ANSI/CSA)

MODEL	Manual Extension Platform				Powered Extension Platform			
	Total Capacity		Extension Capacity		Total Capacity		Extension Capacity	
3215	600 lb. 272 kg	2 Persons	250 lb. 113 kg	1 Person	N/A			
3219	550 lb. 249 kg	2 Persons	250 lb. 113 kg	1 Person	N/A			
3220	900 lb. 408 kg	2 Persons	300 lb. 136 kg	1 Person	800 lb. 363 kg	2 Persons	300 lb. 136 kg	1 Person
3226	500 lb. 227 kg	2 Persons	250 lb. 113 kg	1 Person	N/A			
4620	1300 lb. 590 kg	3 Persons	300 lb. 136 kg	1 Person	1300 lb. 590 kg	3 Persons	300 lb. 136 kg	1 Person
4626	1000 lb. 454 kg	3 Persons	300 lb. 136 kg	1 Person	1000 lb. 454 kg	3 Persons	300 lb. 136 kg	1 Person
4632	700 lb. 318 kg	2 Persons	250 lb. 113 kg	1 Person	N/A			
6826	1200 lb. 544 kg	3 Persons	300 lb. 136 kg	1 Person	1000 lb. 454 kg	3 Persons	300 lb. 136 kg	1 Person
6832	850 lb. 386 kg	3 Persons	300 lb. 136 kg	1 Person	850 lb. 386 kg	3 Persons	300 lb. 136 kg	1 Person

60315AG-ANSI

NOTE: Overall Capacity - Occupants and materials not to exceed rated load.

Table 2.3b Maximum Platform Capacities (Evenly Distributed) (CE)

MODEL	Manual Extension Platform				Powered Extension Platform				Maximum Wind Speed	Tilt Cutout Setting
	Total Capacity		Extension Capacity		Total Capacity		Extension Capacity			
3215	227 kg	2 Persons	113 kg	1 Person	N/A				No Wind	1.5 x 3.5
3219	227 kg	2 Persons	113 kg	1 Person	N/A				No Wind	1.5 x 3.5
3220	408 kg 2 Persons				363 kg 2 Persons				No Wind	1.5 x 3.5
3226	227 kg 2 Persons				N/A				No Wind	1.5 x 3.5
4620	590 kg	3 Persons	136 kg	1 Person	590 kg	3 Persons	136 kg	1 Person	12.5 m/s	1.5 x 3.5
4626	454 kg	3 Persons	136 kg	1 Person	454 kg	3 Persons	136 kg	1 Person	12.5 m/s	1.5 x 3.5
4632	317 kg	2 Persons	113 kg	1 Person	N/A				12.5 m/s	1.5 x 3.5
6826	454 kg	3 Persons	136 kg	1 Person	N/A				12.5 m/s	2 x 4
6832	454 kg	3 Persons	136 kg	1 Person	N/A				12.5 m/s	2 x 4

60315AI-CE-R

NOTE: Overall Capacity - Occupants and materials not to exceed rated load.

BEAUFORT SCALE	Wind Speed				Ground Conditions
	m/s	km/h	ft/s	mph	
3	3.4 – 5.4	12.5 – 19.4	11.5 – 17.75	5 – 12.0	Papers and thin branches move, flags wave
4	5.4 – 8.0	19.4 – 28.8	17.75 – 26.25	12.0 – 18	Dust is raised, paper whirled up, and small branches sway.
5	8.0 – 10.8	28.8 – 38.9	26.25 – 35.5	18 – 24.25	Shrubs with leaves start swaying. Wave crests are apparent in ponds or swamps.
6	10.8 – 13.9	38.9 – 50.0	35.5 – 45.5	24.5 – 31	Tree branches move. Power lines whistle. It is difficult to open an umbrella.
7	13.9 – 17.2	50.0 – 61.9	45.5 – 65.5	31 – 38.5	Whole trees sway. It is difficult to walk against the wind.

60338AC



WARNING

The aerial is equipped with a Load Sensing System. Do not exceed the rated capacity of the aerial platform. Failure to avoid this will prevent operation of all normal controls/functions of the aerial platform. To resume normal operation remove the additional loads.

Table 2.3c Maximum Platform Capacities (Evenly Distributed) (AS)

MODEL	Max. Side Force (N)	Max. Wind (m/s)	Manual Extension Platform				Powered Extension Platform			
			Total Capacity		Extension Capacity		Total Capacity		Extension Capacity	
3215	400	0	227 kg	2 Persons	113 kg	1 Person	N/A			
	200	12.5	227 kg	1 Person	227 kg					
3219	400	0	249 kg	2 Persons	113 kg	1 Person	N/A			
	200	12.5	120 kg	1 Person	120 kg					
3220	400	0	408 kg	2 Persons	136 kg	1 Person	N/A			
	200	12.5	227 kg	1 Person	227 kg					
3226*	400	0	227 kg	2 Persons	113 kg	1 Person	N/A			
	200	12.5	120 kg	1 Person	120 kg					
4620	400	12.5	590 kg	3 Persons	136 kg	1 Person	590 kg	3 Persons	136 kg	1 Person
4626	400	12.5	454 kg	3 Persons	136 kg	1 Person	454 kg	3 Persons	136 kg	1 Person
4632	400	12.5	317 kg	2 Persons	113 kg	1 Person	N/A			
6826	400	12.5	544 kg	3 Persons	136 kg	1 Person	N/A			
6832	400	12.5	454 kg	3 Persons	136 kg	1 Person	N/A			

60315AG-AS

NOTE: Overall Capacity - Occupants and materials not to exceed rated load.

Table 2.4 Torque Specifications

Directional valve mounting bolts	28-32 lbf.in			2.16 – 3.61 Nm				
Wheel mounting bolts	70 lbf.ft			94.92 Nm				
Wheel motor castle nut	200 lbf.ft			271.20 Nm				
Parking brake cylinder rod nut	35 lbf.ft			47.46 Nm				
Cartridge								
	Size							
Torque	08	38	58	10	12	16		
Lbf.ft (max)	20	20	20	25	35	50		
Lbf.in (max)	240	240	240	300	420	600		
Nm (max)	27.12	27.12	27.12	33.90	47.46	67.80		
Coils								
	Size							
Torque	All coils							
Lbf.ft (max)	4 to 5							
Lbf.in (max)	48 to 60							
Nm (max)	5.42 to 6.78							
SAE Plugs								
	Size							
Torque	2	4	5	6	8	10	12	16
Lbf.ft (max)	3	10	15	15	25	25	30	35
Lbf.in (max)	36	120	180	180	300	300	360	420
Nm (max)	4.07	13.56	20.34	20.34	33.90	33.90	40.68	47.46
Newton-meter = Nm			Pound-force foot = lbf.ft			Pound-force inch = lbf.in		

60056AC

Section 3

SYSTEM COMPONENT IDENTIFICATION AND SCHEMATICS

Table of Contents

Charts

3.1	Electrical Symbol Chart	3
3.2	Hydraulic Symbol Chart.....	4
3.3	Wire Number and Color Code	5









































Parts List

3.4	Hydraulic Manifold and Port Identifications.....	6
3.5	Hydraulic Schematic Parts List.....	7
3.6	Electrical Component Parts List	8
3.7	Platform Control Console Diagram	11
3.8	Base Control Console Diagram.....	12
3.9	Scissor Arm Control Cable	13
3.10	Electrical Inverter Option: Schematic & Panel Diagram (ANSI/CSA - Equipped with timer cutout relay)	14



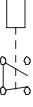
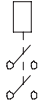
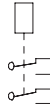

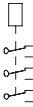











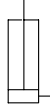

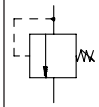
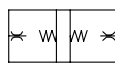







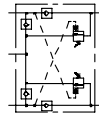







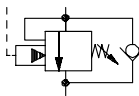

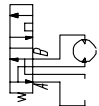
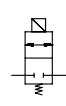

Diagrams and Schematics

3.11	Hydraulic Schematic - Model 3215	15
3.12	Hydraulic Schematic - Model 3219	16
3.13	Main Manifold Harness and Holding Valve Harness (ANSI/CSA).....	17
3.14	Main Manifold Harness and Holding Valve Harness (CE)	18
3.15	Electrical Panel Diagram (ANSI/CSA)	19
3.16	Electrical Panel Diagram (CE)	20
3.17	Electrical Panel Diagram (EE Rated).....	21
3.18	Limit Switch Assemblies Diagram	22
3.19	Horn/Tilt Switch/Flashing Light Diagram.....	23
3.20	Control Module and Beeper Diagram (CE).....	24
3.21	Electrical Schematic (ANSI/CSA - equipped with no options).....	25
3.22	Electrical Schematic (ANSI/CSA - equipped with all options)	26
3.23	Electrical Schematic (CE - equipped with all options)	27
3.24	Electrical Schematic (ANSI/CSA EE Rated - equipped with no options)	28
3.25	Electrical Schematic (ANSI/CSA EE Rated - equipped with all options).....	29

3.1 Electrical Symbol Chart

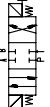
 CIRCUIITS CROSSING NO CONNECTION	 HOURMETER	 KEY SWITCH	 LIMIT SWITCH N.O.
 CIRCUIITS CONNECTED	 LIGHT	 FOOT SWITCH	 LIMIT SWITCH N.O. HELD CLOSED
 BATTERY	 HYDRAULIC VALVE COIL	 TOGGLE SWITCH	 LIMIT SWITCH N.C.
 GROUND	 PROPORTIONAL HYDRAULIC VALVE COIL	 PUSH BUTTON	 LIMIT SWITCH N.C. HELD OPEN
 FUSE	 ELECTRIC MOTOR	 ROTARY SWITCH	 SILICON CONTROLLED RECTIFIER
 CIRCUIT BREAKER	 HORN	 LIMIT SWITCH	 PROXIMITY SWITCH
 VOLT METER	 EMERGENCY STOP BUTTON	 CAM OPERATED LIMIT SWITCH	 PNP TRANSISTOR
 CAPACITOR	 RESISTOR	 TILT SWITCH	 NPN TRANSISTOR
 POTENTIOMETER	 LEVEL SENSOR	 SINGLE POLE SINGLE THROW RELAY	 PRESSURE/ VACUUM SWITCH
 SINGLE POLE DOUBLE THROW RELAY	 DOUBLE POLE SINGLE THROW RELAY	 DOUBLE POLE DOUBLE THROW RELAY	 TEMPERATURE SWITCH
 TRIPLE POLE DOUBLE THROW RELAY	 DIODE	 RHEOSTAT	

3.2 Hydraulic Symbol Chart

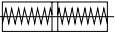
	LINE CROSSING		VARIABLE DISPLACEMENT PUMP		SHUTTLE VALVE		VELOCITY FUSE
	LINE JOINED		HAND PUMP		ACCUMULATOR, GAS CHARGED		SINGLE ACTING CYLINDER
	HYDRAULIC TANK		RELIEF VALVE		CUSHION CYLINDER		DOUBLE ACTING CYLINDER
	HYDRAULIC FILTER WITH BYPASS		PRESSURE REDUCING VALVE		PRESSURE SWITCH		DOUBLE ACTING DOUBLE RODDED CYLINDER
	ELECTRIC MOTOR		FIXED ORIFICE		MOTION CONTROL VALVE		SPRING APPLIED HYDRAULIC RELEASED BRAKE
	ENGINE		ADJUSTABLE FLOW CONTROL		FLOW DIVIDER COMBINER		BRAKE CYLINDER
	FIXED DISPLACEMENT PUMP		CHECK VALVE		COUNTER BALANCE VALVE		ROTARY ACTUATOR
	VARIABLE DISPLACEMENT HYDRAULIC MOTOR		OIL COOLER		VALVE COIL		BI DIRECTIONAL HYDRAULIC MOTOR
	SERIES PARALLEL HYDRAULIC MOTOR		TWO POSITION TWO WAY NORMALLY CLOSED VALVE		TWO POSITION THREE WAY VALVE		THREE POSITION FOUR WAY CLOSED CENTER OPEN PORT
	TWO POSITION TWO WAY NORMALLY OPEN VALVE		TWO POSITION THREE WAY VALVE		THREE POSITION FOUR WAY CLOSED CENTER CLOSED PORT		
	PRESSURE TRANSDUCER		MAIN LINES Solid		PILOT LINES Dashed		
	SERVO						

3.3 Wire Number and Color Code

WIRE NO.	WIRE COLOR	WIRE NO.	WIRE COLOR	WIRE NO.	WIRE COLOR	WIRE NO.	WIRE COLOR	WIRE NO.	WIRE COLOR
00	WHT	20	ORG/BLU	44	YEL/WHT	67	ORG/BRN	92	GRN SHLD
000	WHT	21	WHT/RED	45	YEL/ORG	68	GREY	93	BLK SHLD
B1	BLU/PINK	23	BLK/WHT	46	RED/BLK	69	WHT/GRN	95	YEL/GREY
01	PUR/BLK	24	BLU/BLK	47	PUR/ORG	70	ORG/PINK	96	WHT/GREY
02	WHT	25	BRN/BLK	48	YEL/GREY	71	RED/ORG	97	ORG/GREY
03	GRN/PUR	26	BLU/YEL	49	GRN/RED	72	RED/BRN	98	RED SHLD
04	RED/YEL	27	RED/BLK/WHT	50	BRN	73	RED/PINK	98A	BLK SHLD
05	PUR	28	GRN	51	BLK/GRN	74	GRN/ GREY	99	BLK/GREY
06		29	GREY/ORG	52	GRN/BLU	75	GREY/PUR	103	BLK/PUR
07	RED	30	RED/GRN	53	BRN/RED	76	BRN/BLU	104	GRN/ORG
08	PUR/WHT	31	RED/WHT	54	PUR/RED	77	BRN/GREY	105	GRN/BRN
09	YEL	32	GRN/BLK	55	YEL/PUR	78	RED/BLU	106	GRN/PINK
10	BLU/WHT	33	GRN/WHT	56	YEL/BLK	79	BRN/PUR	107	BLK/BLU
11	WHT/ORG	34	ORG/BLK	57	BRN/GRN	80	GREY/ WHT	108	YEL/BRN
12	RED/YEL/ BLK	35	ORG/WHT	58	WHT/PUR	81	GREY/BLK	109	GRN/YEL
13	ORG	36	RED/PUR	59	YEL/BLU	82	BRN/WHT	110A	BLU
14	BLK	37	WHT/RED/ BLK	60	WHT/BLU	83	BLU/GREY	110B	BRN
15	BLU	38	ORG/RED	61	GREY/BRN	84	WHT/BLK/ PUR	111	GREY/GRN
16	WHT/BLK	39	BLK/RED	62	GREY/RED	85	GREY/BLU	112	BLU/ORG
17	BLU/GRN	40	BLU/RED	63	GREY/YEL	86/87	PUR/BLU	113	BLU/BRN
18	GRN/BLU	41	BLU/PUR	64	WHT/BRN	88	BLK/ORG	114	YEL/RED
19	ORG/GRN	42	PINK	65	YEL/PINK	90	RED/GREY	115	WHT/PUR
22	PUR/GRN	43	WHT/YEL	66	ORG/YEL	91	RED SHLD	118	PUR/PINK

This table is to be used as a wire number/color reference for all electrical drawings and schematics. All wire numbers will retain their original color coding, for example if wire 7 is red, wire 7A, 7B, and 7C will also be red.

3.4 Hydraulic Manifold and Port Identifications

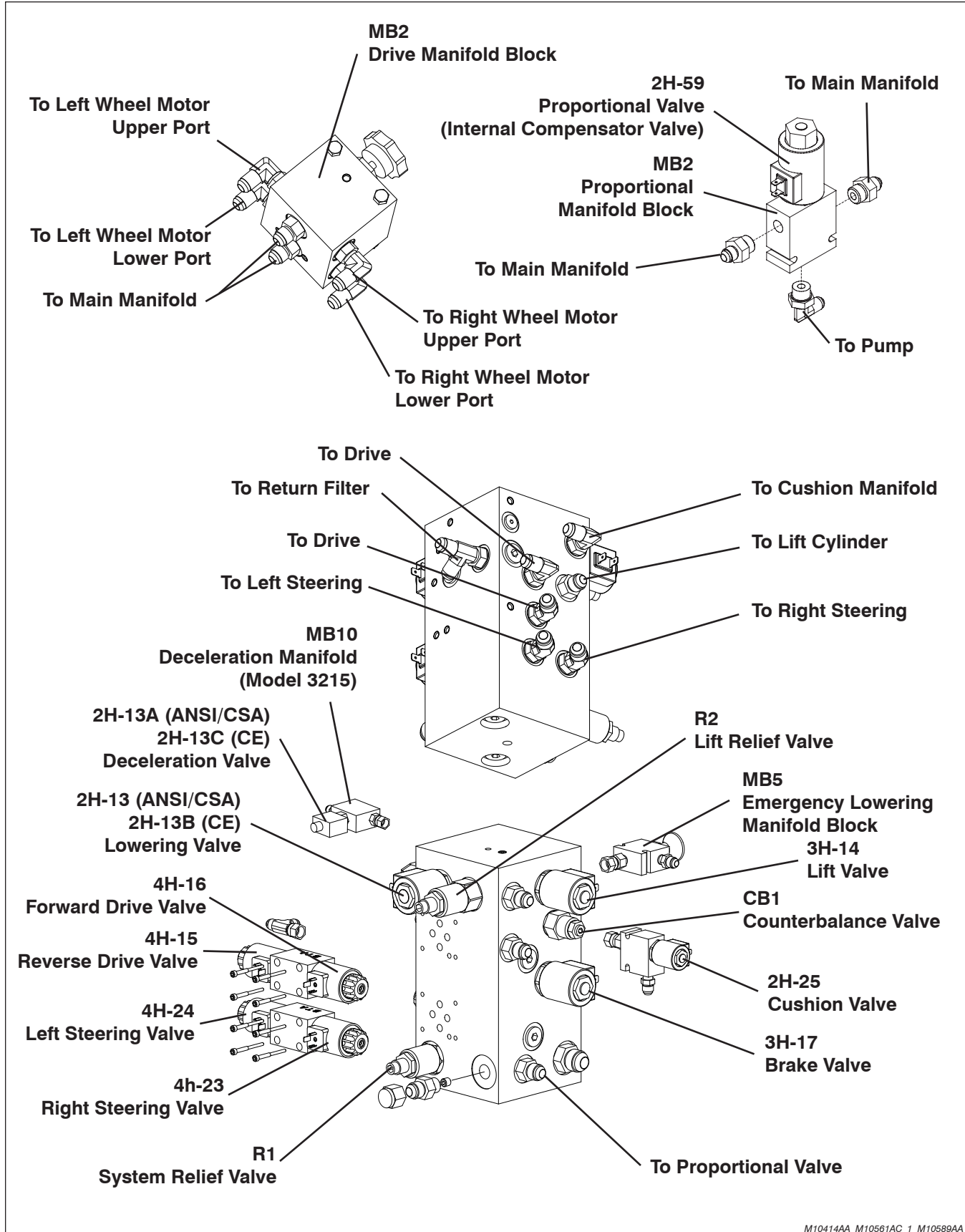

M10414AA M10561AC_1 M10589AA

3.5 Hydraulic Schematic Parts List

Index No.	Skyjack Part No.	Qty.	Description
2H-13	103655	1	VALVE, Lowering (ANSI/CSA)
2H-13B	103655	1	VALVE, Lowering (CE)
2H-13A	134822	1	VALVE, Deceleration (ANSI/CSA - Model 3215)
2H-13C	134822	1	VALVE, Deceleration (CE - Model 3215)
2H-13-1	107629	1	VALVE, Holding (ANSI/CSA)
2H-13B-1	107629	1	VALVE, Holding (CE)
2H-25	128113	1	VALVE, Cushion
2H-59B	132749	1	VALVE, Proportional control
3H-14	106273	1	VALVE, Lift
3H-17	103623	1	VALVE, Brake
4H-15	128317	1	VALVE, "Hytos" (Reverse drive) (includes 4H-16)
4H-16	128317	1	VALVE, "Hytos" (Forward drive) (includes 4H-15)
4H-23	128317	1	VALVE, "Hytos" (Right steer) (includes 4H-24)
4H-24	128317	1	VALVE, "Hytos" (Left steer) (includes 4H-23)
C2	130709	1	CYLINDER, Lift
C3	121087	1	CYLINDER, Steer
C4	127667	1	CYLINDER, Brake
CB1	147888	1	VALVE, Counterbalance (2750 psi)
F1	109568	1	FILTER, Return
MI	139412	1	MOTOR, Hydraulic drive (White Hydraulics)
M2	139412	1	MOTOR, Hydraulic drive (White Hydraulics)
MB1	127629	1	MANIFOLD BLOCK (Main)
MB2	139307	1	MANIFOLD BLOCK (Drive)
MB3	128113	1	MANIFOLD BLOCK (Cushion valve)
MB4	130480	1	MANIFOLD BLOCK (Holding valve)
MB5	126761	1	MANIFOLD BLOCK (Lowering valve)
MB9	132748	1	MANIFOLD BLOCK (Proportional control)
MB10	136419	1	MANIFOLD BLOCK, Deceleration valve (Model 3215)
O2	130046	1	ORIFICE, Lowering (0.063" diameter) (Model 3219)
O3	108002	1	ORIFICE, Cushion (0.040" diameter)
O4	130407	1	ORIFICE, Brake (0.051" diameter)
O5	108002	2	ORIFICE, Steering (0.04" diameter)
O6	105281	1	ORIFICE, Emergency Lowering (0.067" diameter)
O7	147656	1	ORIFICE, Drive (0.024" diameter)
P1	147661	1	PUMP, Hydraulic
PT1	134431	1	TRANSDUCER, Pressure (2000 psi) (Model 3215)
	134432	1	TRANSDUCER, Pressure (3000 psi) (Model 3219)
R1	104534	1	VALVE, System relief
R2	104534	1	VALVE, Lift relief
V1	107271	1	VALVE, Emergency lowering
V2	103136	1	VALVE, Free-wheeling

3.6 Electrical Component Parts List

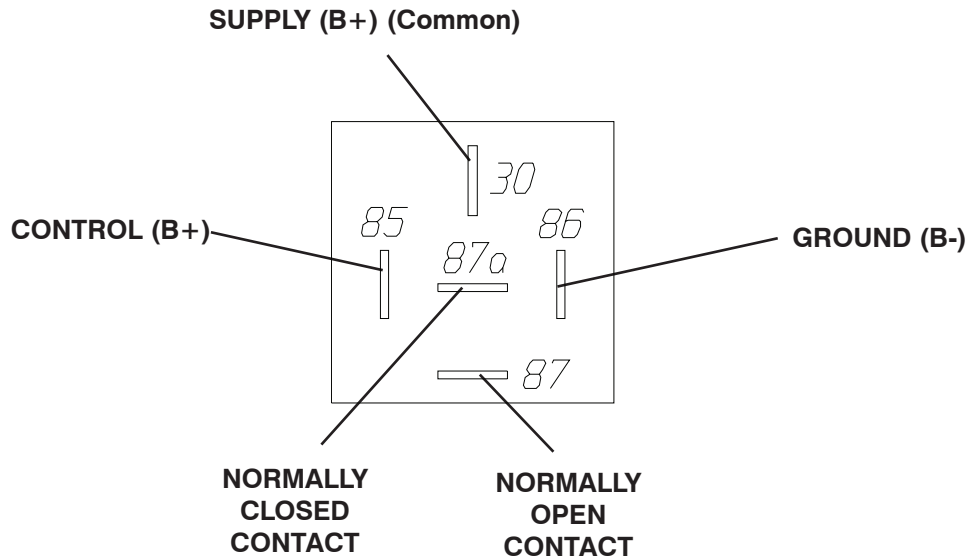

Index No.	Skyjack Part No.	Qty.	Description
17CCR	108589	1	RELAY, 24 Volt (Cushion)
17CR	108589	1	RELAY, 24 Volt (Steer)
17CR1	108589	1	RELAY, 24 Volt (Transfer)
21ACR	108589	1	RELAY, 24 Volt (Proportional)
28CR	108589	1	RELAY, 24 Volt (Tilt switch) (ANSI/CSA)
28CR1	108589	1	RELAY, 24 Volt (Tilt switch) (CE)
28CR2	108589	1	RELAY, 24 Volt (Down) (CE)
28ECR1	108589	1	RELAY, 24 Volt (Auxillary tilt) (CE)
28ECR2	108589	1	RELAY, 24 Volt (Auxillary down) (CE)
L1CR	127154	1	RELAY, 12 Volt (Charger cutout)
2H-13	103605	1	COIL, 24 Volt (Lowering valve) (ANSI/CSA)
2H-13B	103605	1	COIL, 24 Volt (Lowering valve) (CE)
2H-13A	137006	1	COIL, 24 Volt (Deceleration valve) (ANSI/CSA - Model 3215)
2H-13C	137006	1	COIL, 24 Volt (Deceleration valve) (CE - Model 3215)
2H-13-1	104493	1	COIL, 24 Volt (Holding valve) (ANSI/CSA)
2H-13B-1	104493	1	COIL, 24 Volt (Holding valve) (CE)
2H-25	103605	1	COIL, 24 Volt (Cushion)
2H-59	115370	1	COIL, 24 Volt (Proportional valve)
3H-14	106273	1	COIL, 24 Volt (Lift valve)
3H-17	103623	1	COIL, 24 Volt (Brake valve)
4H-15	128320	1	COIL, 24 Volt (Reverse drive spool valve) (Hytos)
4H-16	128320	1	COIL, 24 Volt (Forward drive spool valve) (Hytos)
			Parts list continued on the following page.

3.6 Electrical Component Parts List

Index No.	Skyjack Part No.	Qty.	Description
Parts list continued on the following page.			
4H-23	128320	1	COIL, 24 Volt (Right steer spool valve) (Hytos)
4H-24	128320	1	COIL, 24 Volt (Left steer spool valve) (Hytos)
B1-B4	\$	4	BATTERY, 6 Volt (Trojan #T2200)
AT1	130440	1	TRANSDUCER, Angle (CE)
BC	128537	1	CHARGER, Battery (24 Volt)
BCI	122093	1	BATTERY CHARGE INDICATOR
BP-29	103057	1	BEEPER (28 Volt) (ANSI/CSA)
BP-29	117967	1	BEEPER (28 Volt) (CE)
C1	146475	1	CONTACTOR, Motor (24 Volt)
CAP1	103319	1	CAPACITOR (1000 uF, 35 Volt)
CAP2	110699	1	CAPACITOR (0.47 uF, 50 Volt) (ANSI/CSA)
CB1	117325	1	CIRCUIT BREAKER, 15 Amp
CB2	117325	1	CIRCUIT BREAKER, 15 Amp
CM1	130439	1	CONTROL MODULE, Integrated Sensor (CE)
CRD1	146640	-	PLATFORM CONTROL CABLE ASSEMBLY
CRD2	146592	-	SCISSOR ARM CONTROL CABLE ASSEMBLY (Model 3219)
	146601	-	SCISSOR ARM CONTROL CABLE ASSEMBLY (Model 3215)
CRD3	146585	-	ELECTRIC PANEL CONTROL CABLE ASSEMBLY
DCM1	147664	1	MOTOR, 24 Volt
F1	310517	1	FUSE, 300 Amp
FL-22	121477	1	FLASHING LIGHT 24VDC (superior universal)
FL-29	103743	1	FLASHER (option) (ANSI/CSA)
H1	146649	1	HORN, Operator (Low tone)
LED-1	147061	1	POWER INDICATOR LIGHT (Platform control console)
LED-2	147061	1	POWER INDICATOR LIGHT (Base control console)
LS1A	121975	1	LIMIT SWITCH (High speed)
LS1B	121975	1	LIMIT SWITCH (High speed) (ANSI/CSA)
LS4	139228	1	LIMIT SWITCH (Pothole protection) (Battery tray)
LS5	139227	1	LIMIT SWITCH (Pothole protection) (Hydraulic tray)
LS6	121975	1	LIMIT SWITCH (Drive override)
LS7	121975	1	LIMIT SWITCH (Deceleration)
PT1	134431	1	TRANSDUCER, Pressure (2000 psi) (CE - Model 3215)
	134432	1	TRANSDUCER, Pressure (3000 psi) (CE - Model 3219)
RST1	119629	1	RESISTOR, 2.7K Ohms
RST2	147335	1	RESISTOR, 16 Ohms (25W)
RST3	116505	1	RESISTOR, Low voltage protection
S1	119725	1	SWITCH, Main power disconnect
S2	147054	2	N.O. CONTACT (Raise/Lower)
S3	147053	3	N.C. CONTACT (Lift/Drive)
	147054	3	N.O. CONTACT (Lift/Drive) (without power extension platform)
		4	N.O. CONTACT (Lift/Drive) (with power extension platform)
Parts list continued on the following page.			

3.6 Electrical Component Parts List (Continued)

Index No.	Skyjack Part No.	Qty.	Description
Parts list continued on the following page.			
S4	147053	2	N.C. CONTACT (Emergency stop) (Platform control console)
S7	123994	1	CONTROLLER ASSEMBLY, Proportional
S7-1	122869	1	SWITCH, Neutral
S7-2	122877	1	SWITCH, Right steer
S7-3	122877	1	SWITCH, Left steer
S7-6	122872	1	SWITCH, Enable pushbutton
S8	147054	1	N.O. CONTACT (Operator's horn)
S10	147053	2	N.C. CONTACT (Off/Platform)
	147054	1	N.O. CONTACT (Base)
S28	147053	1	N.C. CONTACT (Emergency stop) (Base control console)
TS1	146658	1	TILT SWITCH
TT	103336	1	HOURMETER
\$ - Purchase locally.			

3.7 Platform Control Console Diagram

AB

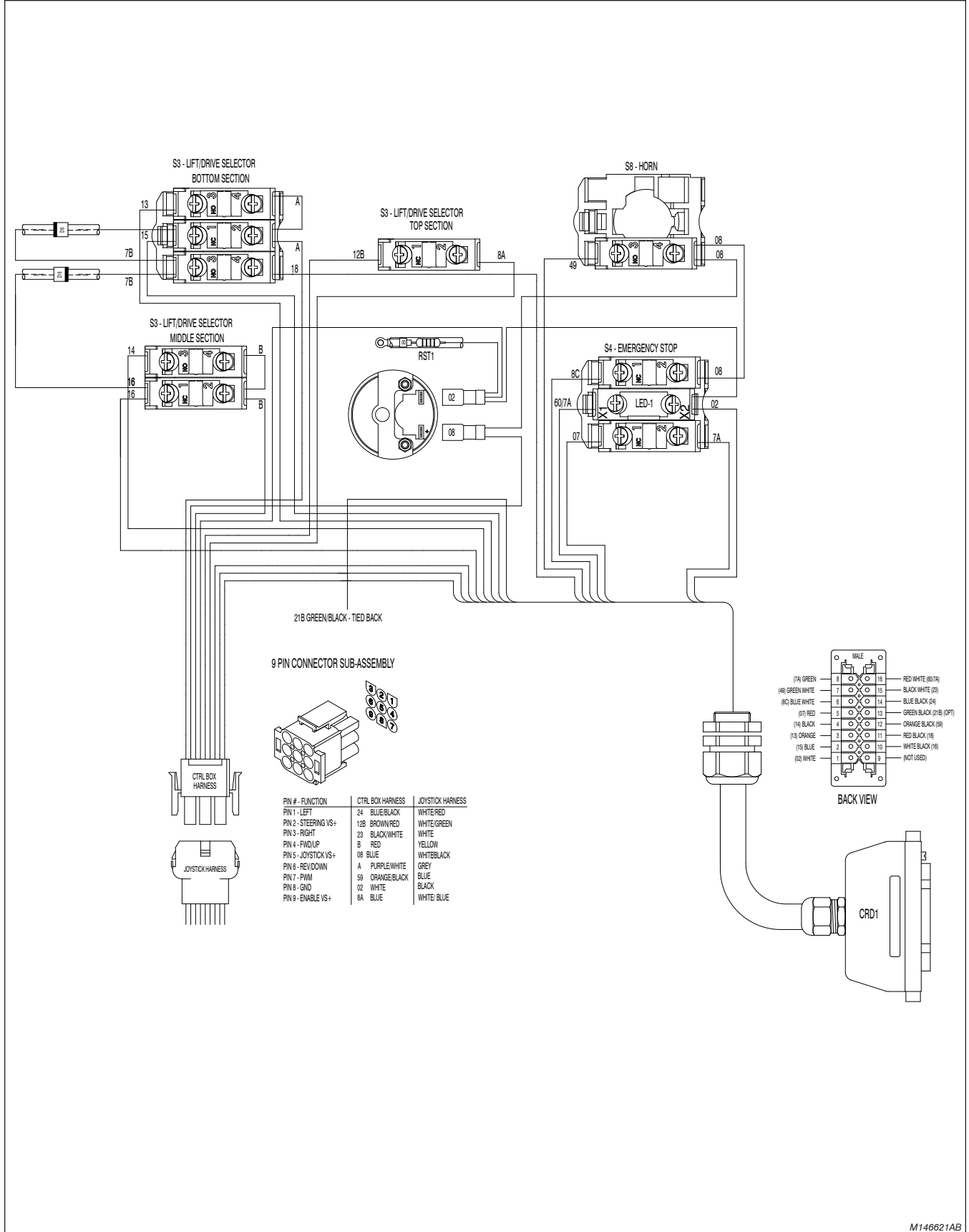

M146621AB

3.8 Base Control Console Diagram

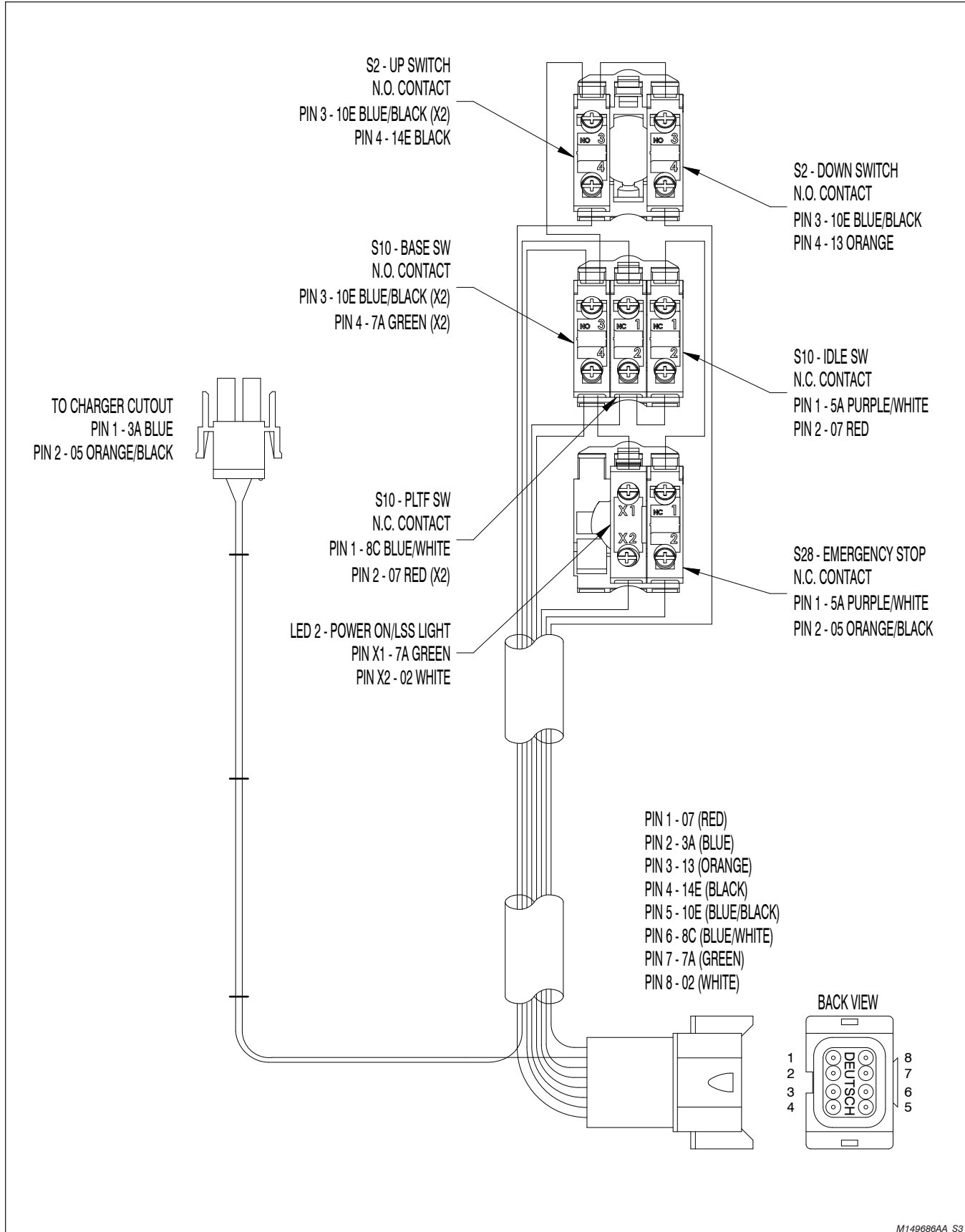

M149686AA_S3

3.9 Scissor Arm Control Cable

CONTROL CABLE OPTIONS		
WIRE COLOUR	EUROPE WIRE NUMBER	N.A WIRE NUMBER
GREEN/BLACK	21B	21B
RED/WHITE	60	7A

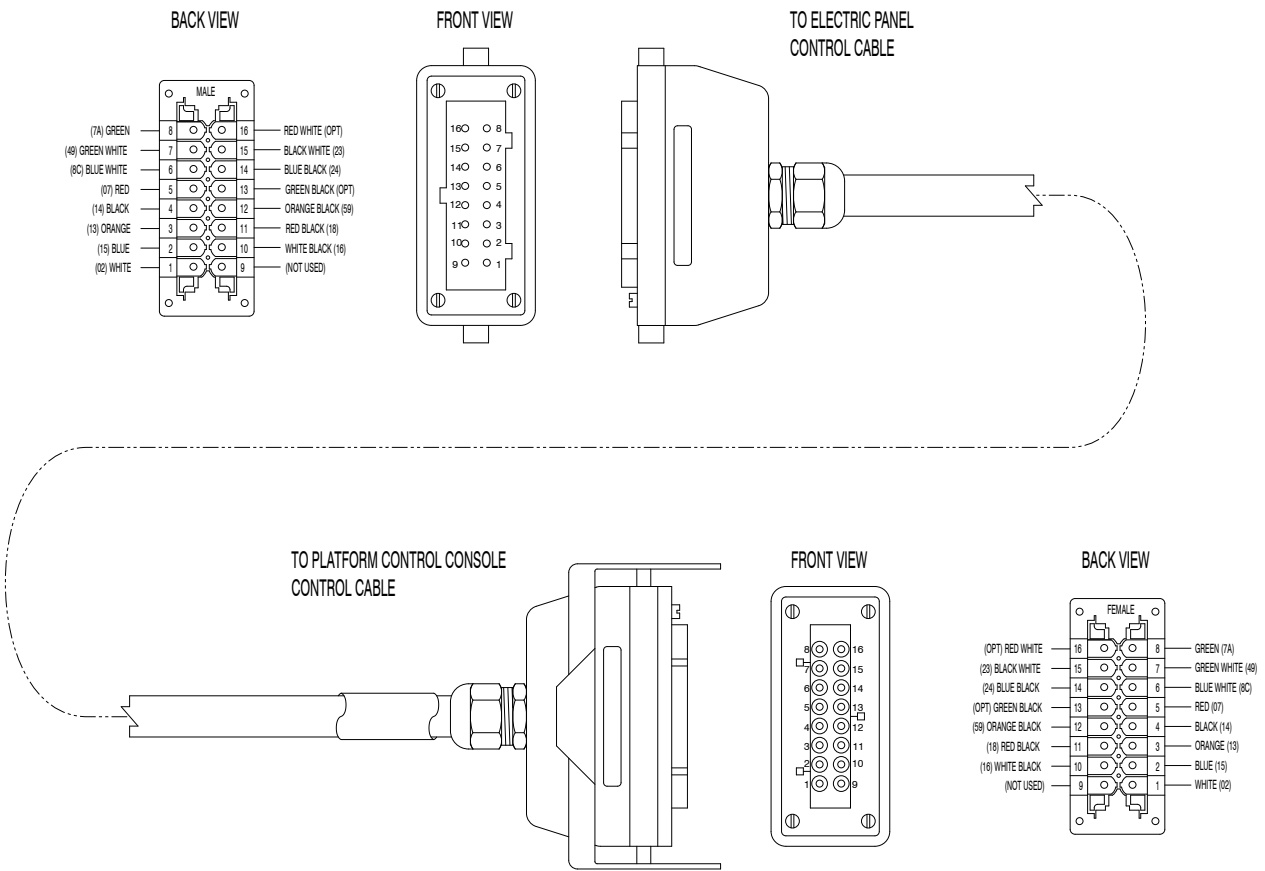

M146650AB_S3

3.10 Electrical Inverter Option: Schematic & Panel Diagram
(ANSI/CSA - Equipped with timer cutout relay)

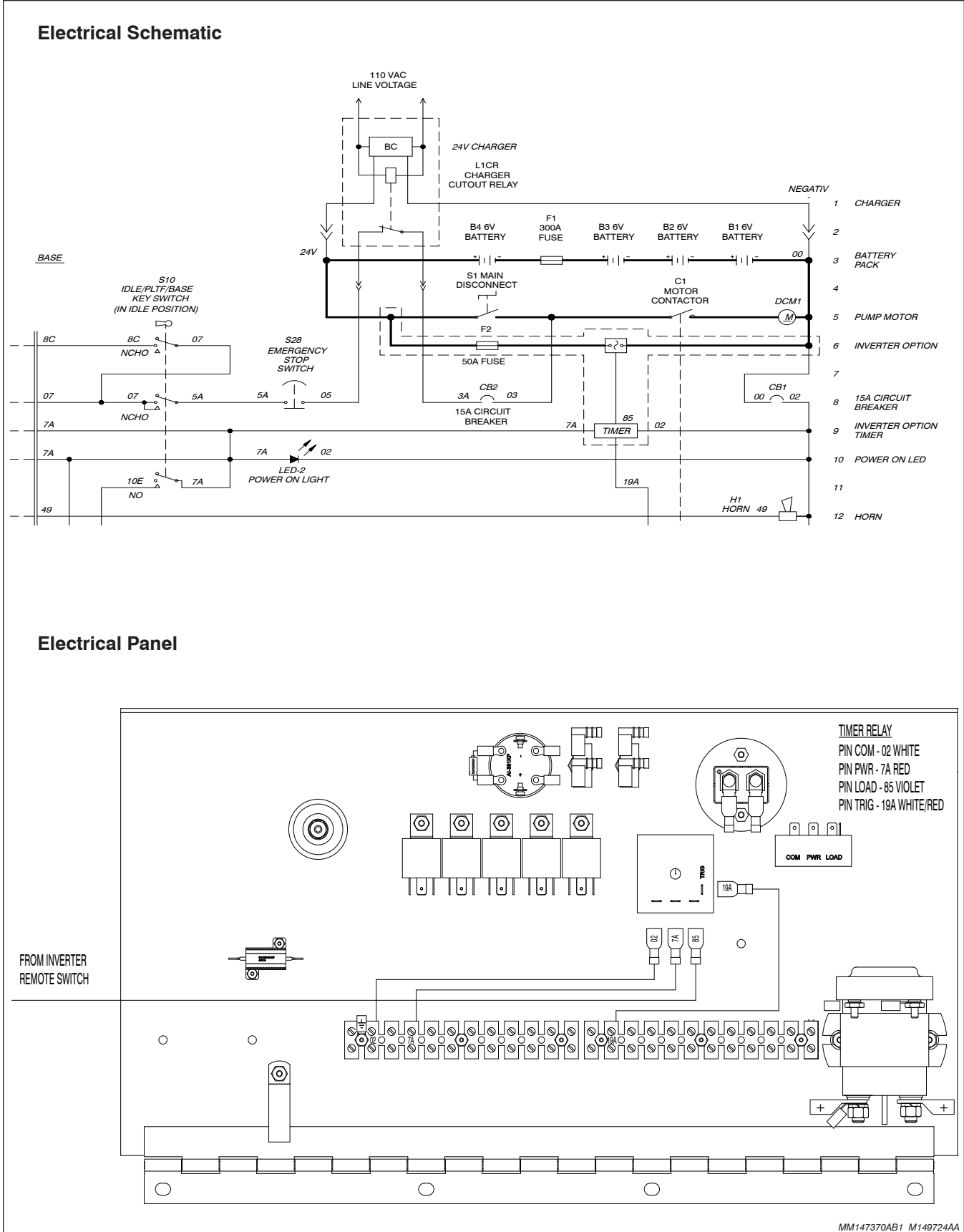

3.11 Hydraulic Schematic - Model 3215

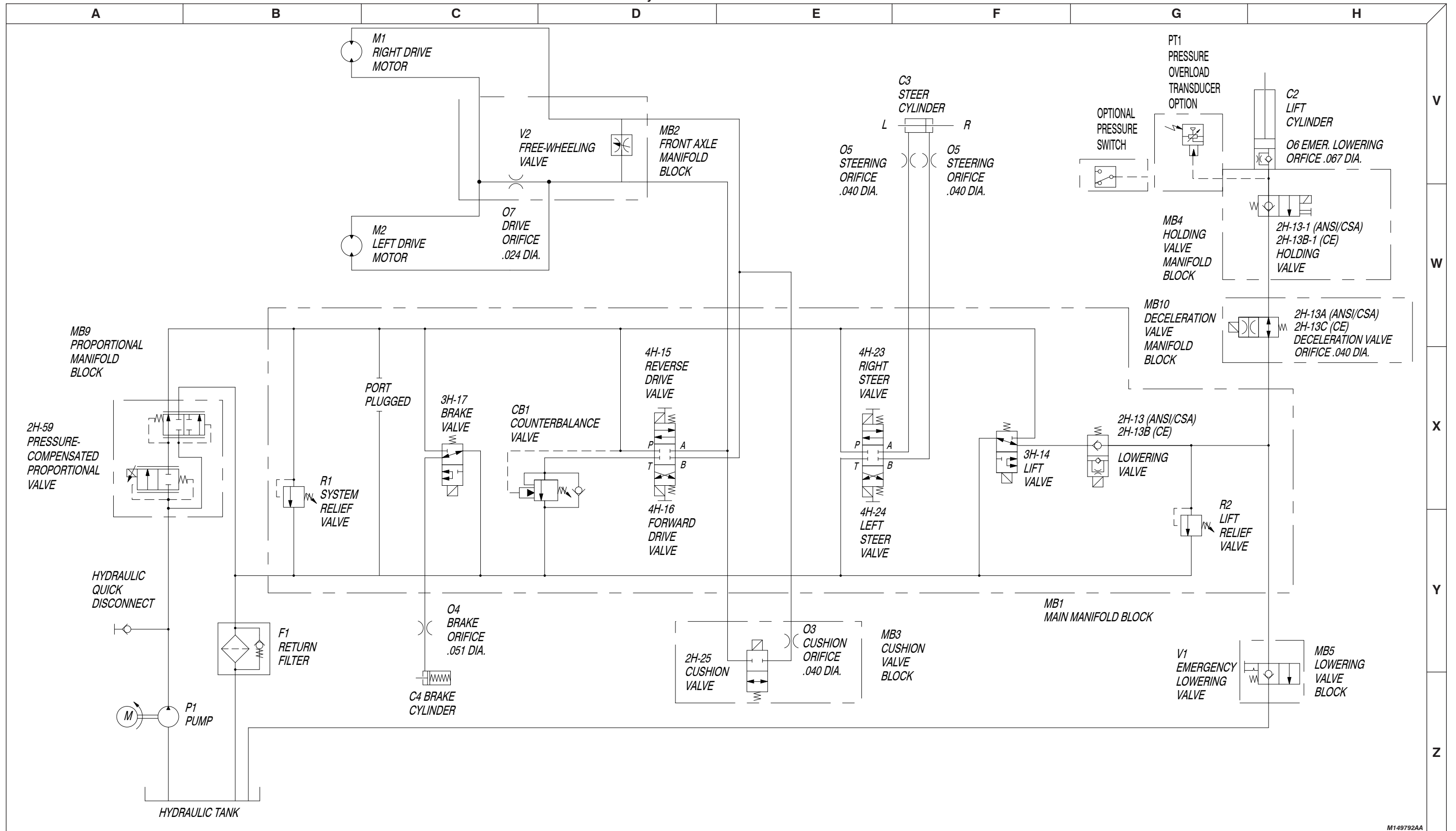

M149792AA

3.12 Hydraulic Schematic - Model 3219

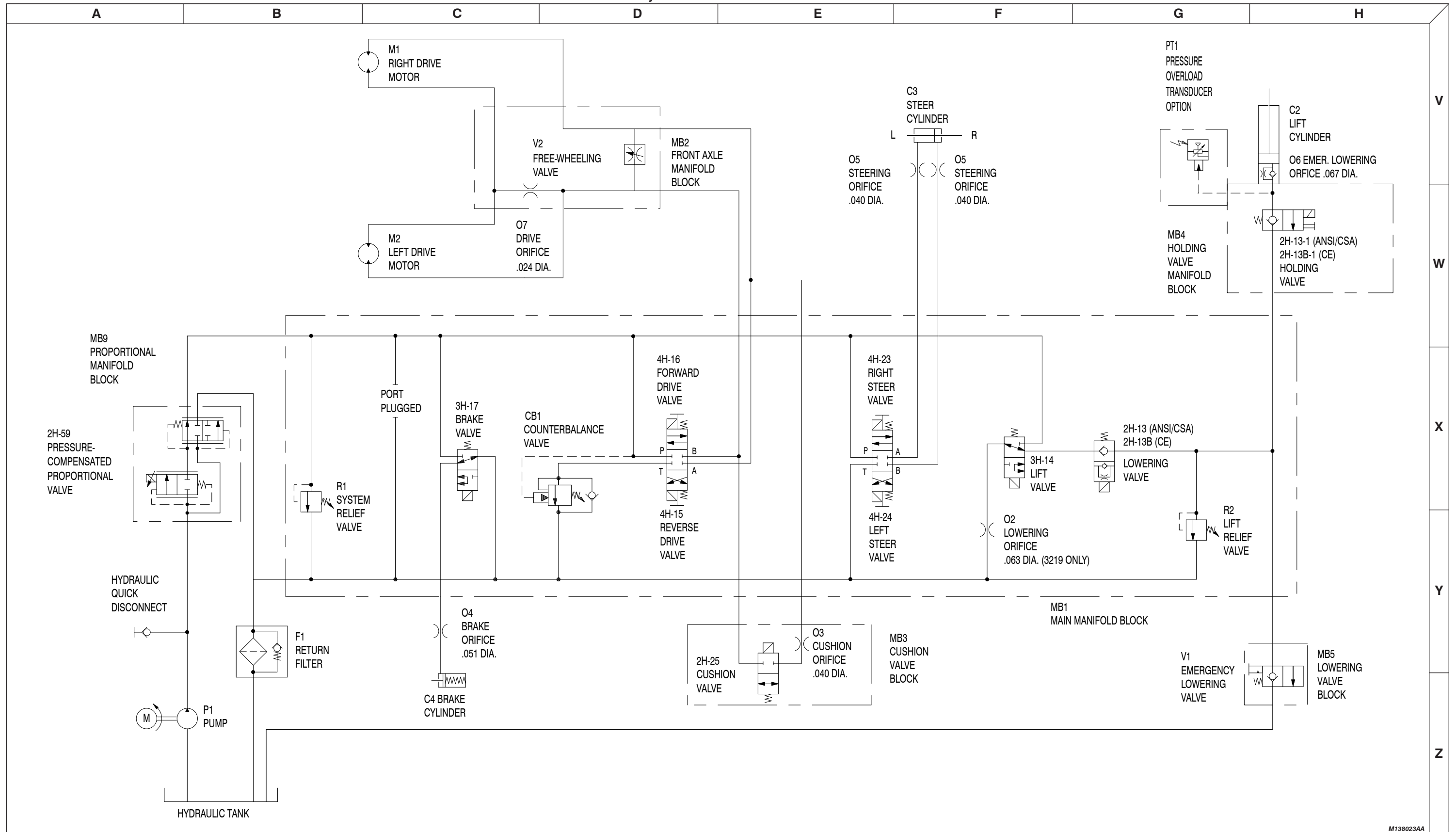

M138023AA

3.13 Main Manifold Harness and Holding Valve Harness (ANSI/CSA)

AB

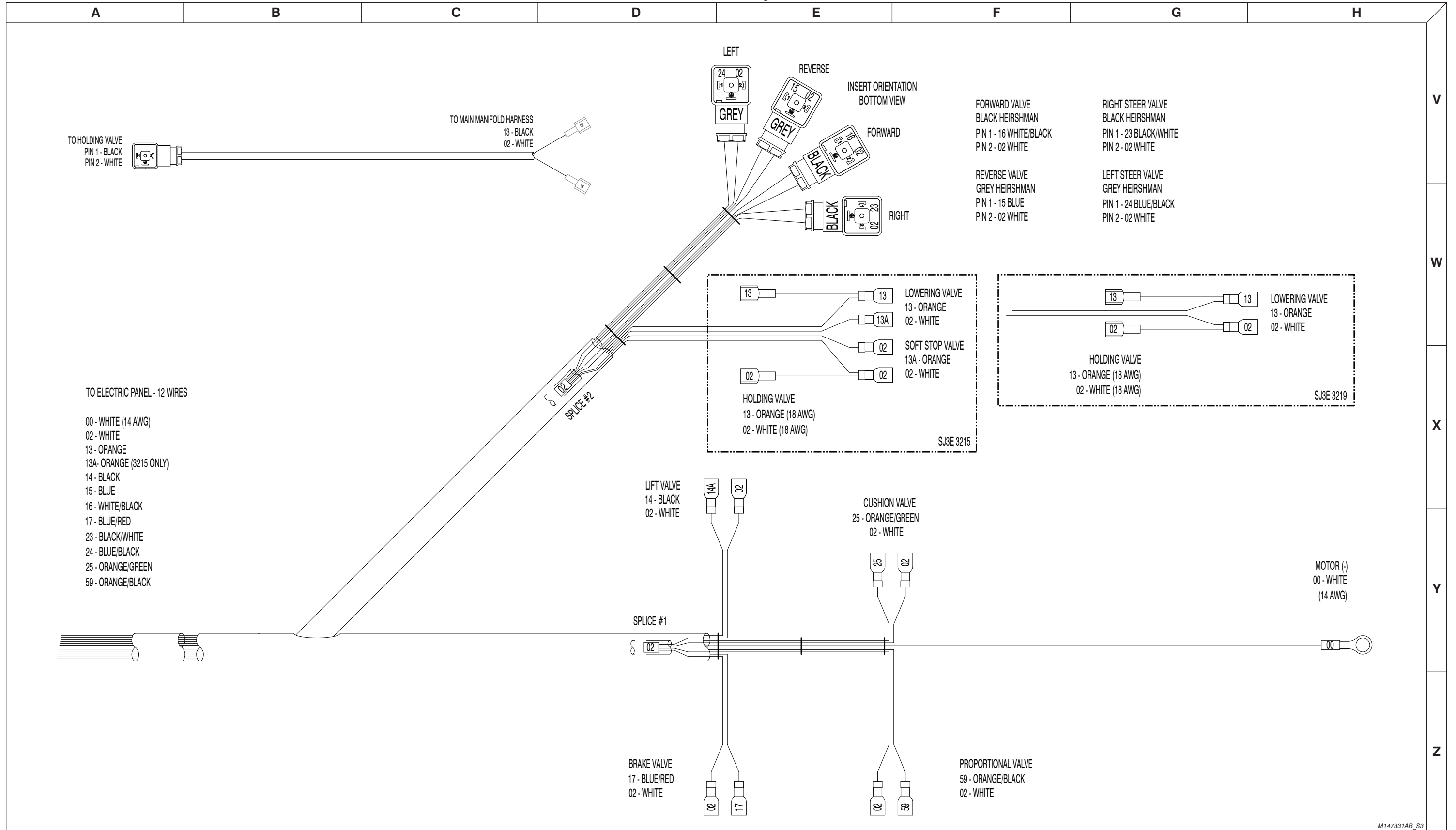

3.14 Main Manifold Harness and Holding Valve Harness (CE)

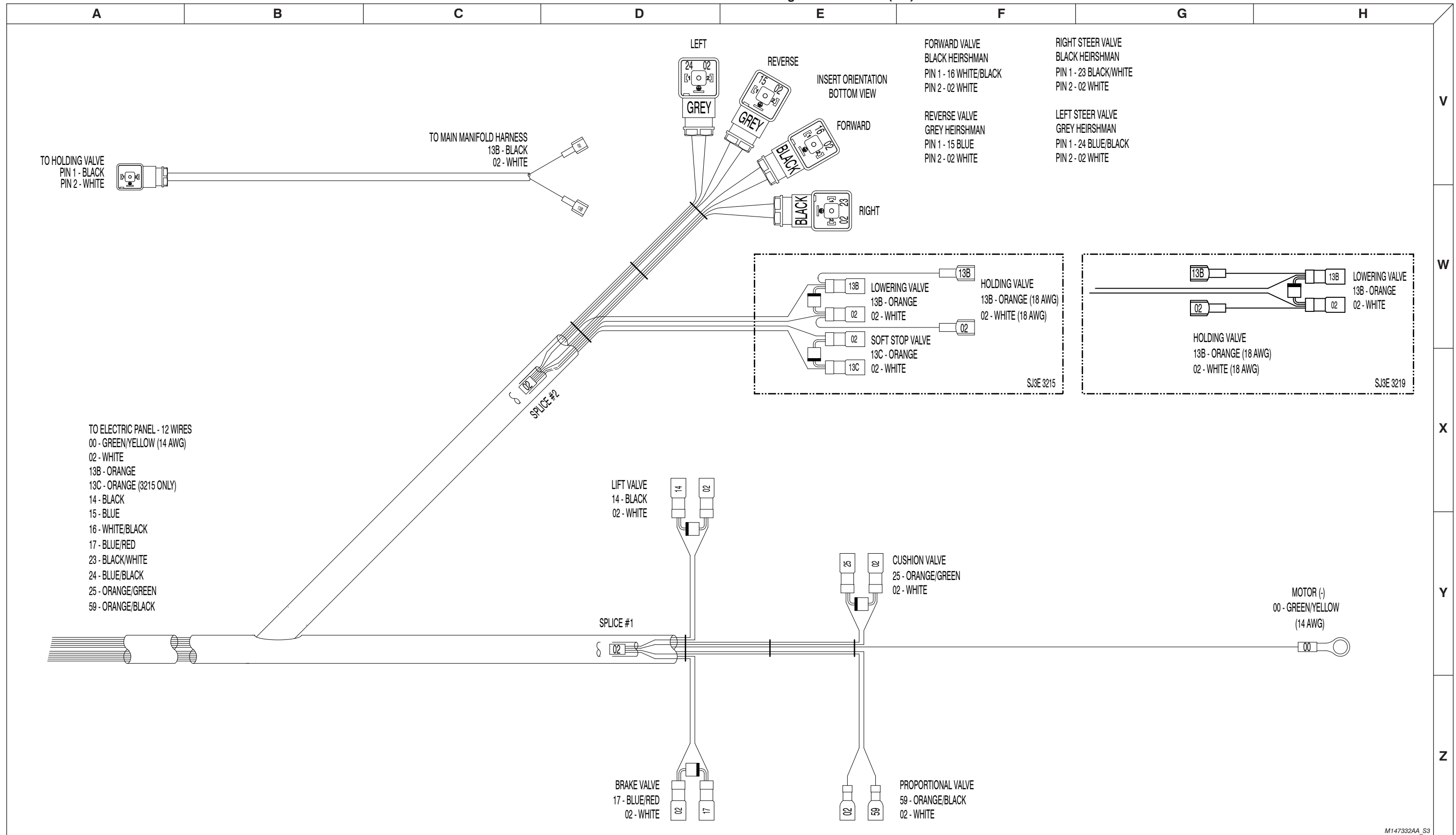

3.15 Electrical Panel Diagram (ANSI/CSA)

AB

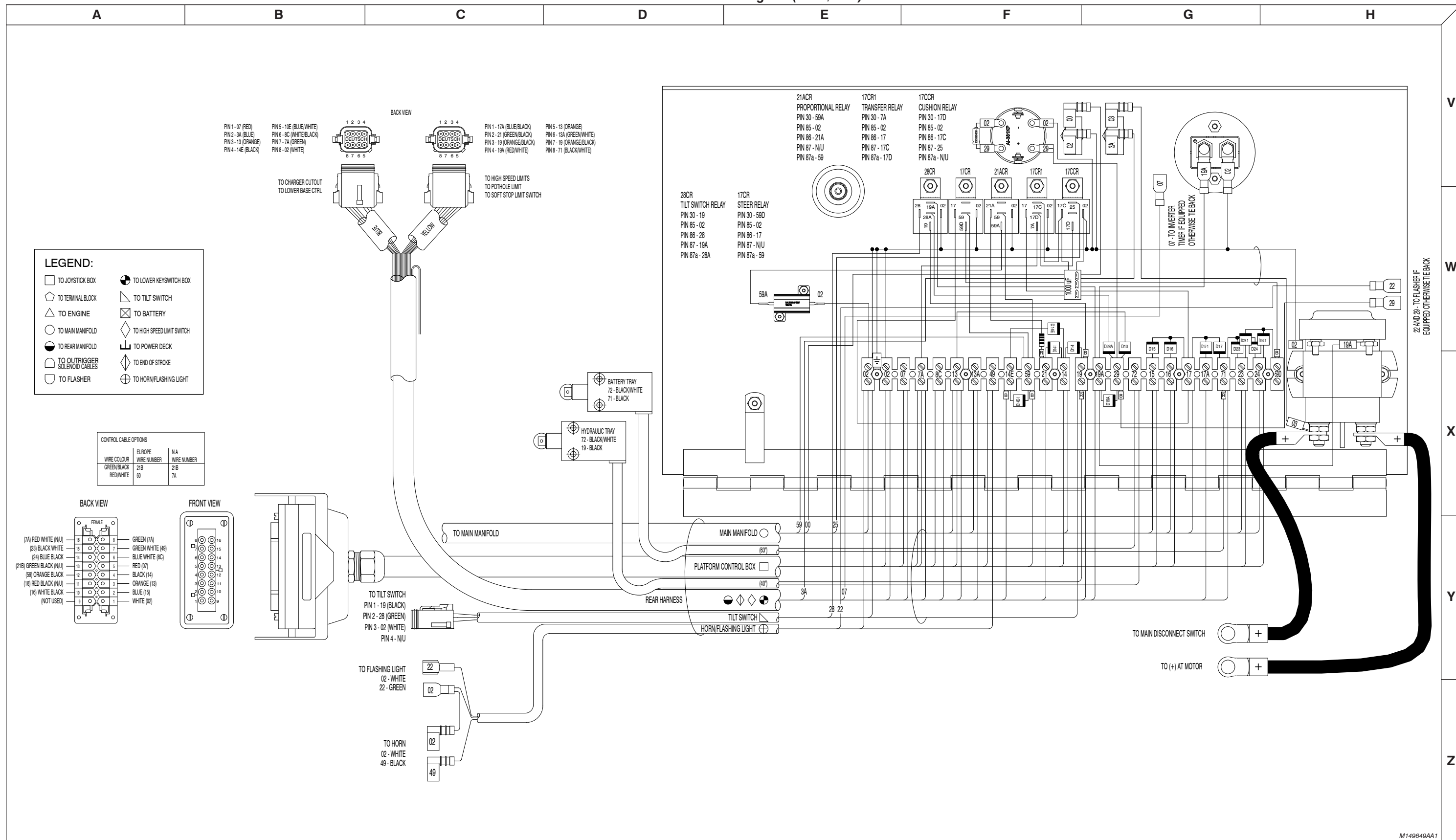

M149649AA1

3.16 Electrical Panel Diagram (CE)

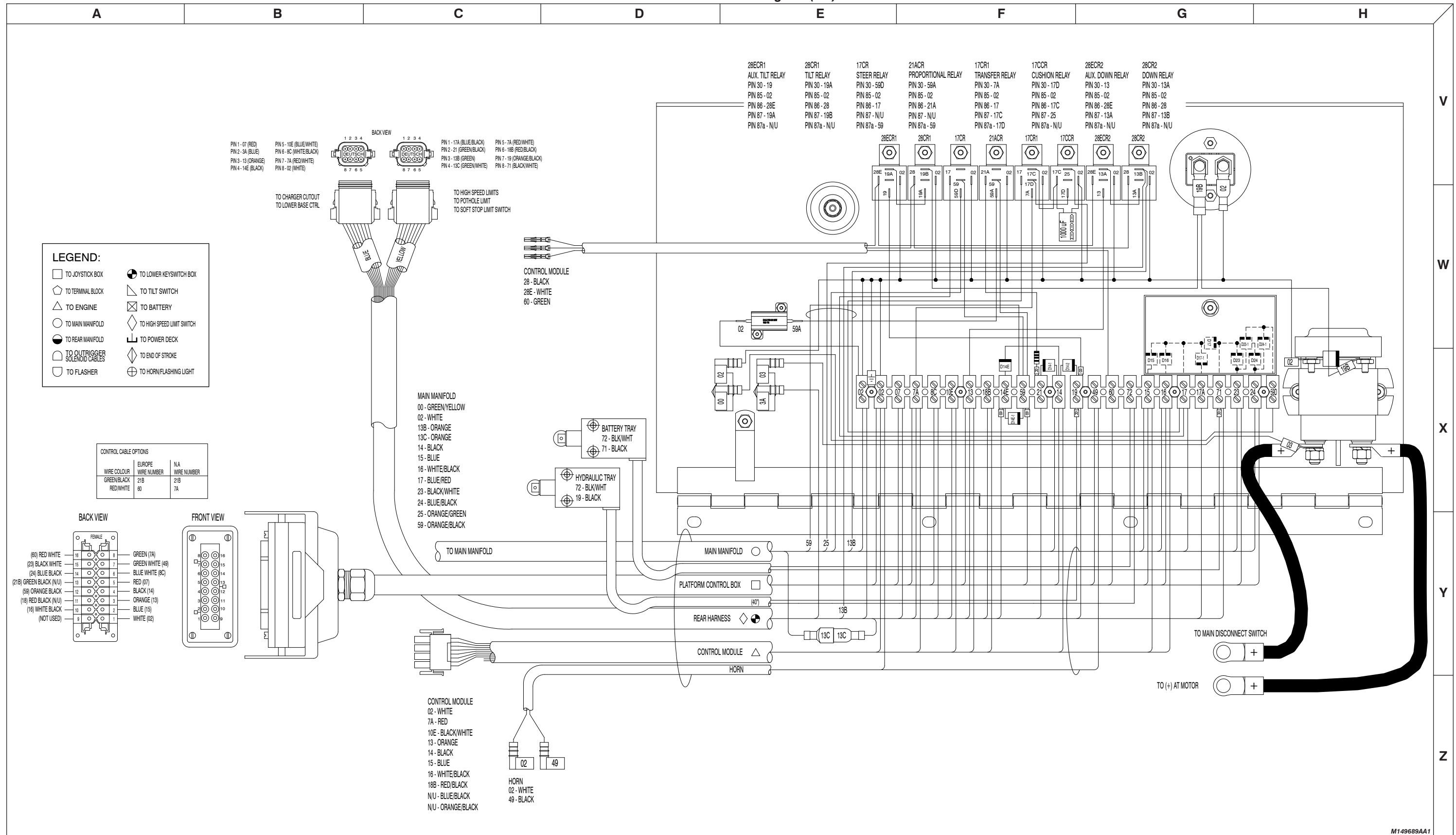

3.17 Electrical Panel Diagram (EE Rated)

AB

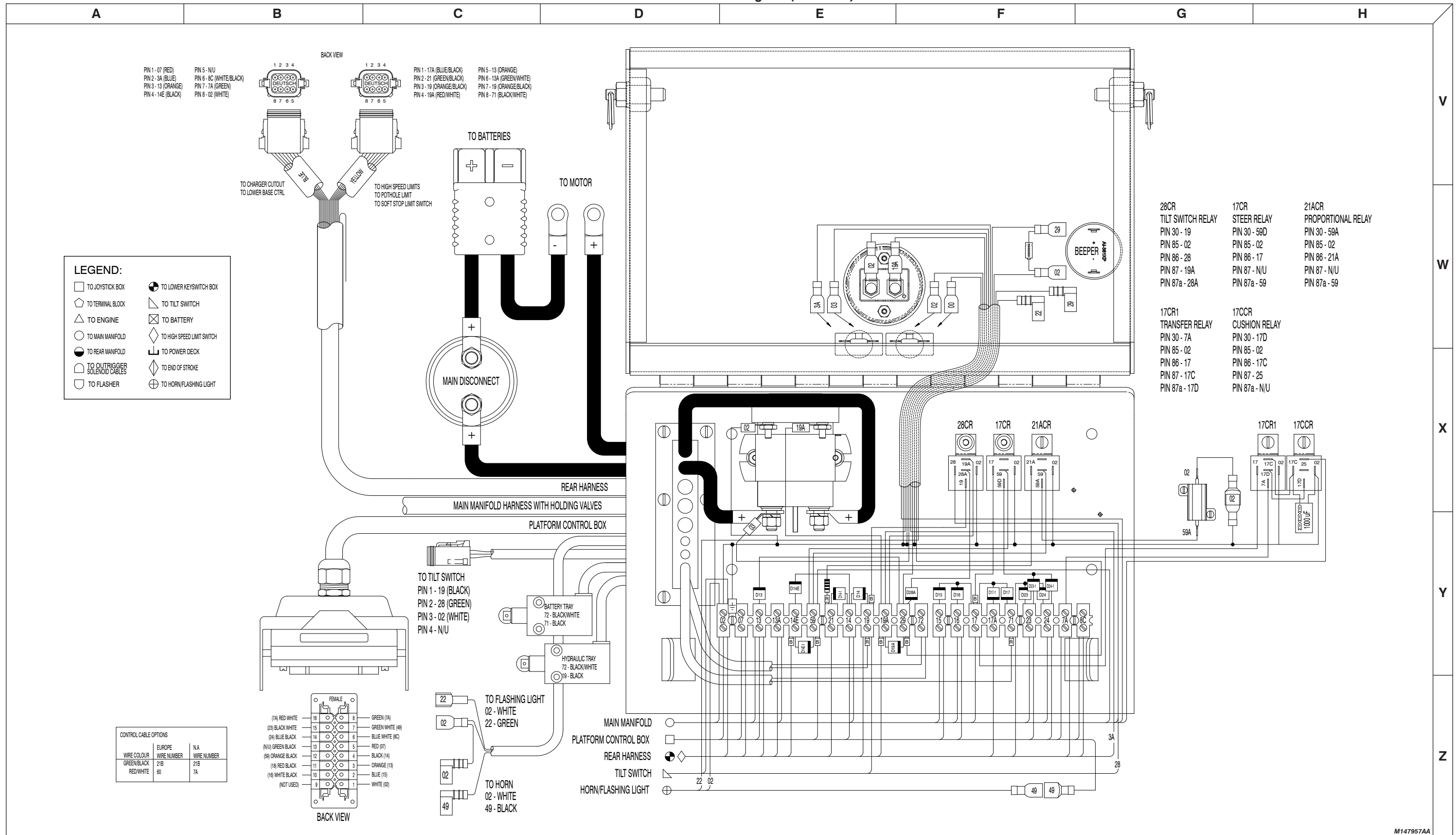

V

W

X

Y

Z

M147957AA

3.18 Limit Switch Assemblies Diagram

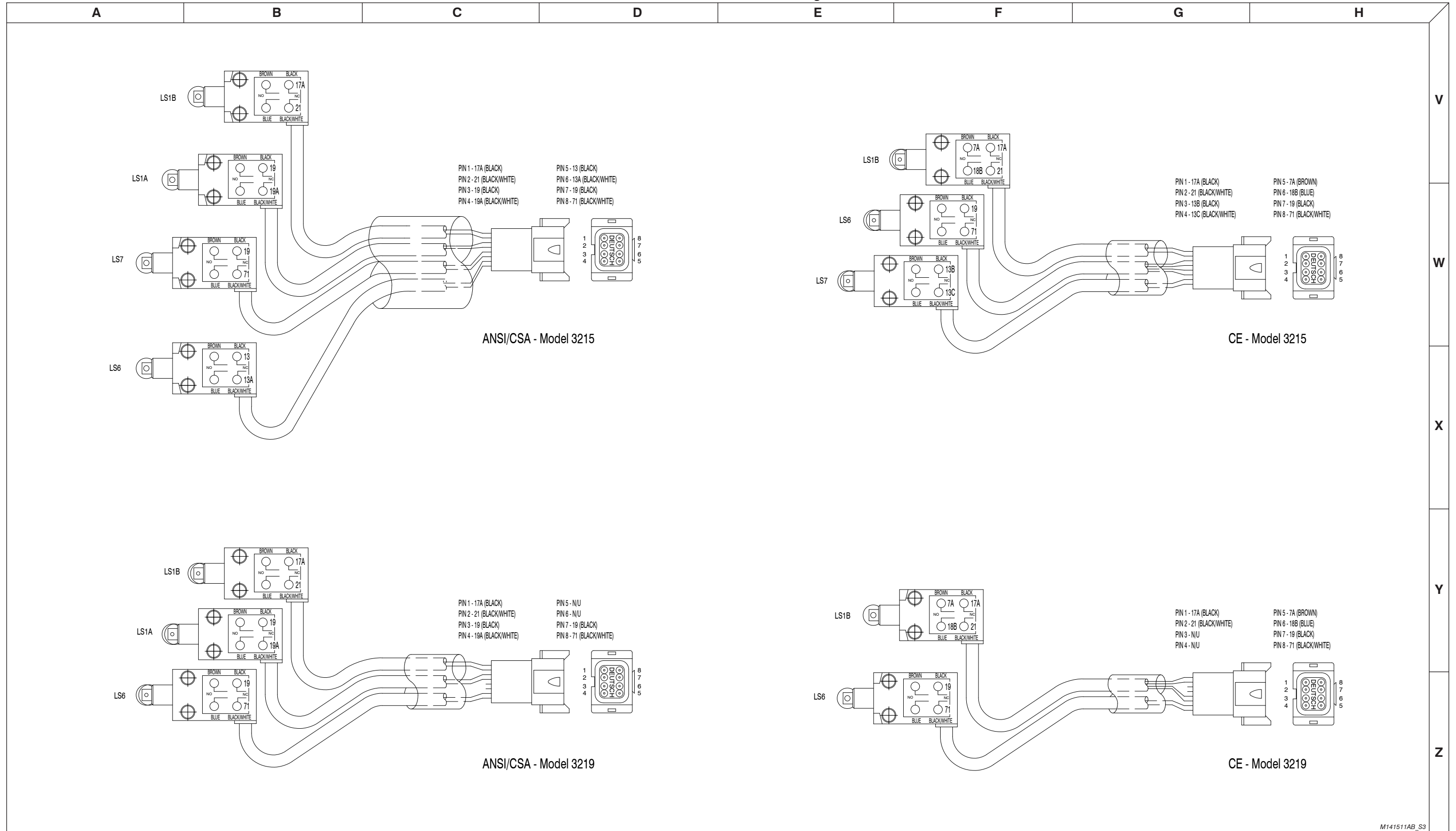

M141511AB_S3

3.19 Horn/Tilt Switch/Flashing Light Diagram

A B C D E F G H

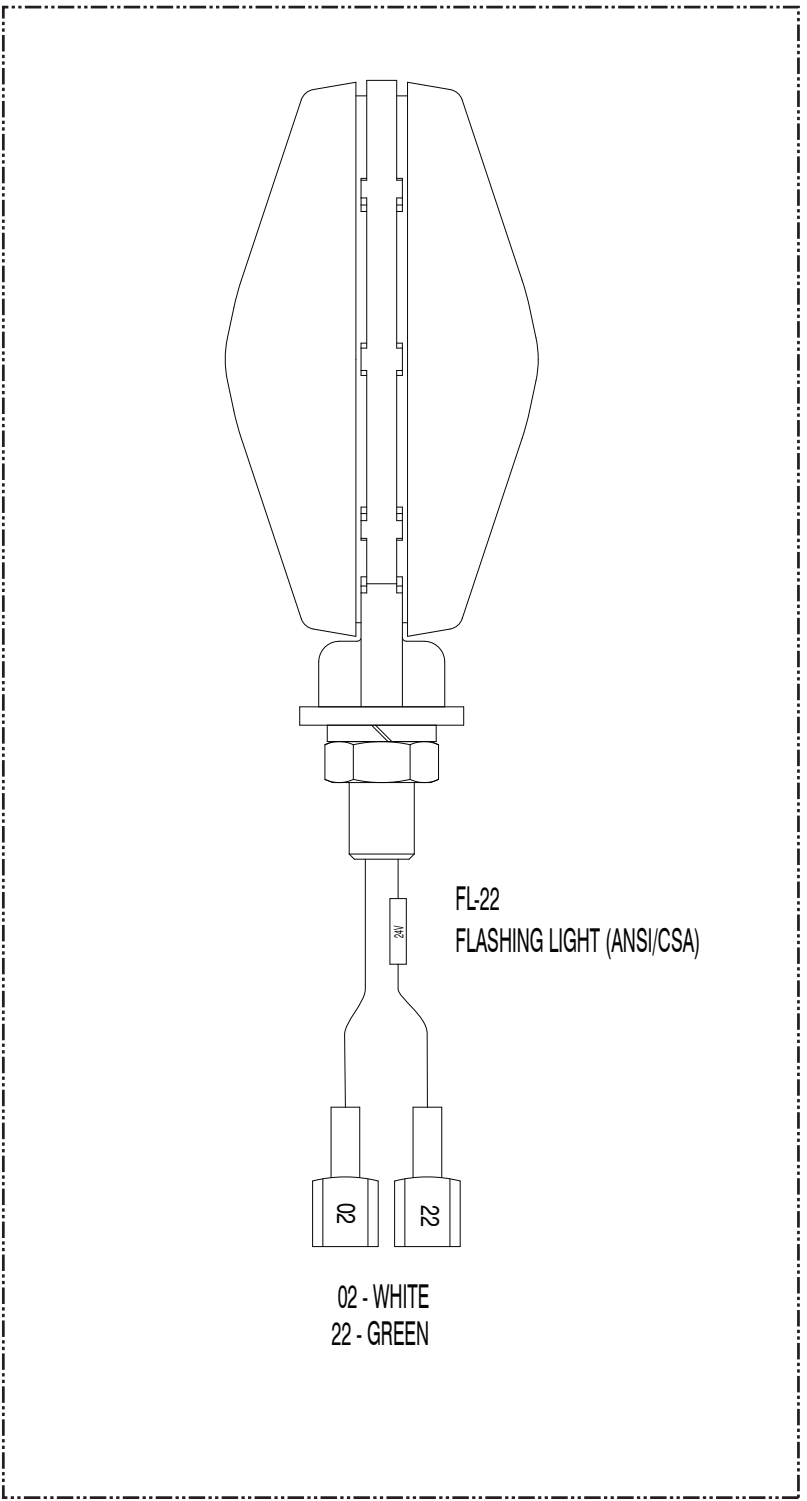
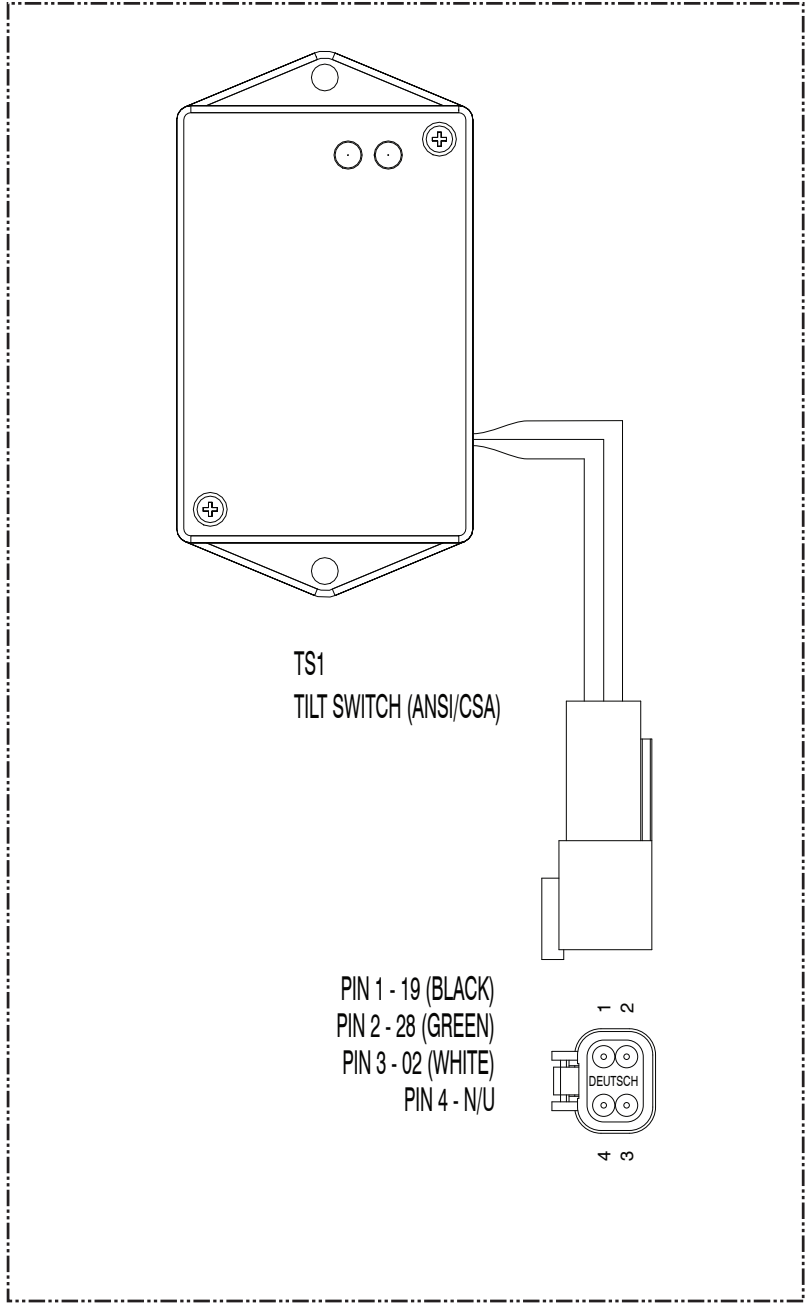
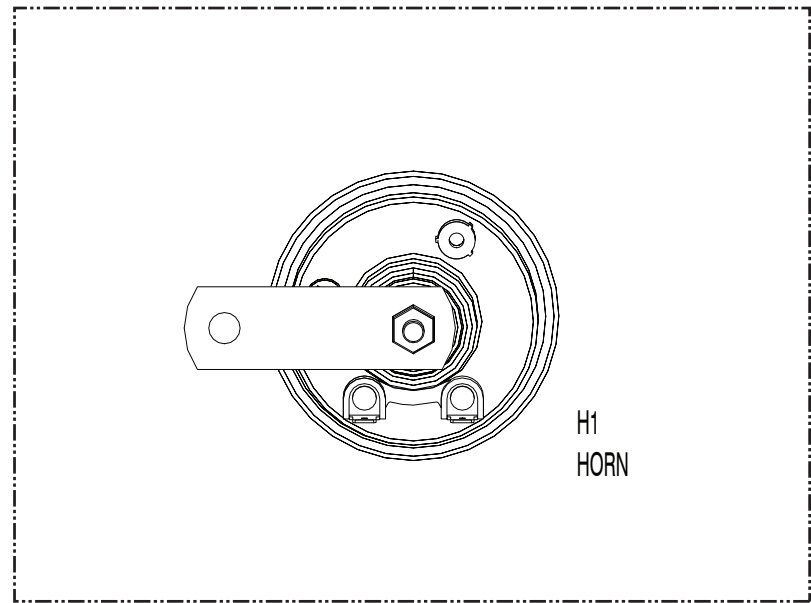

V
W
X
Y
Z

M146648AA_S3

3.20 Control Module and Beeper Diagram (CE)

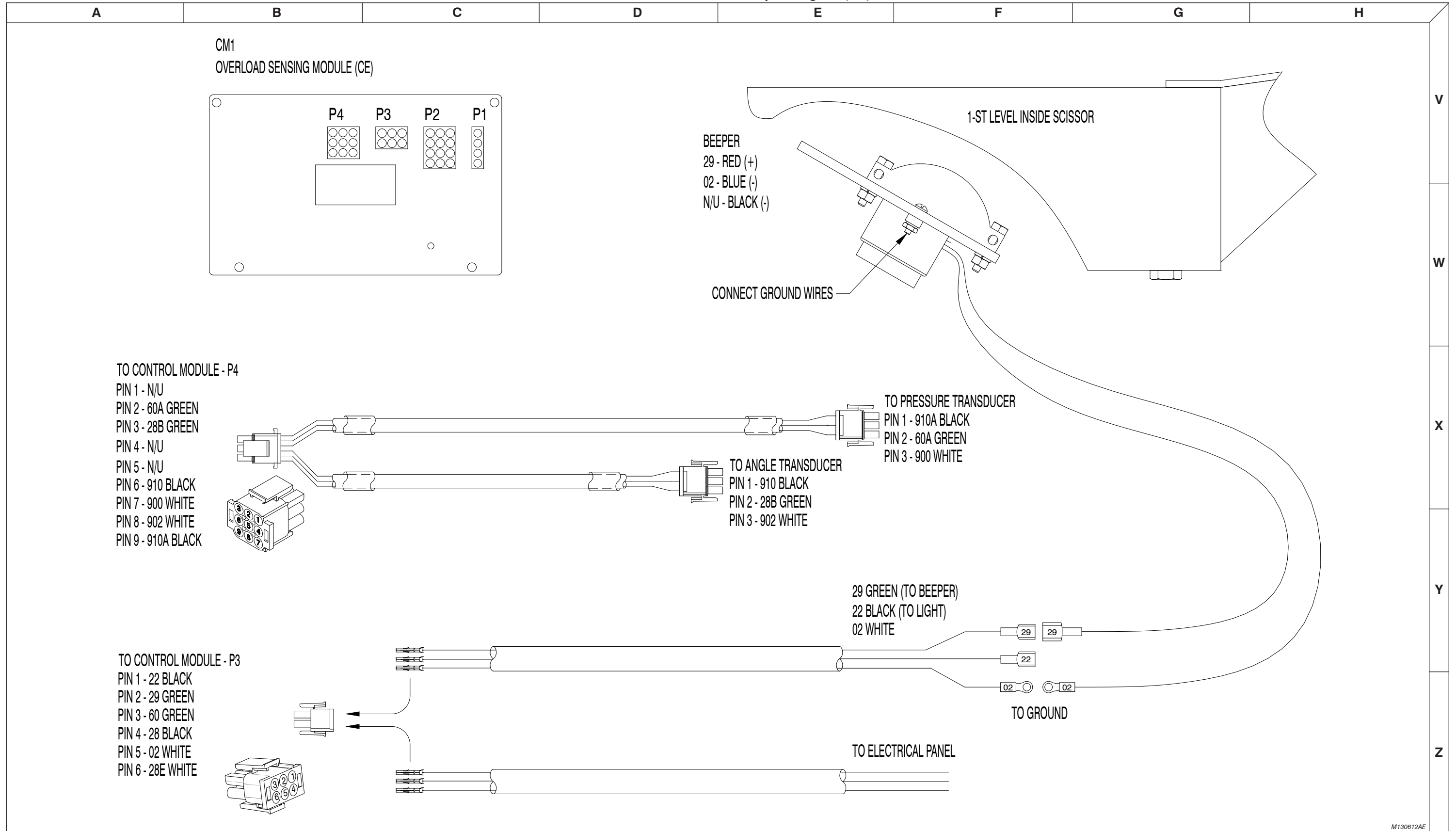

M130612AE

3.21 Electrical Schematic (ANSI/CSA - equipped with no options)

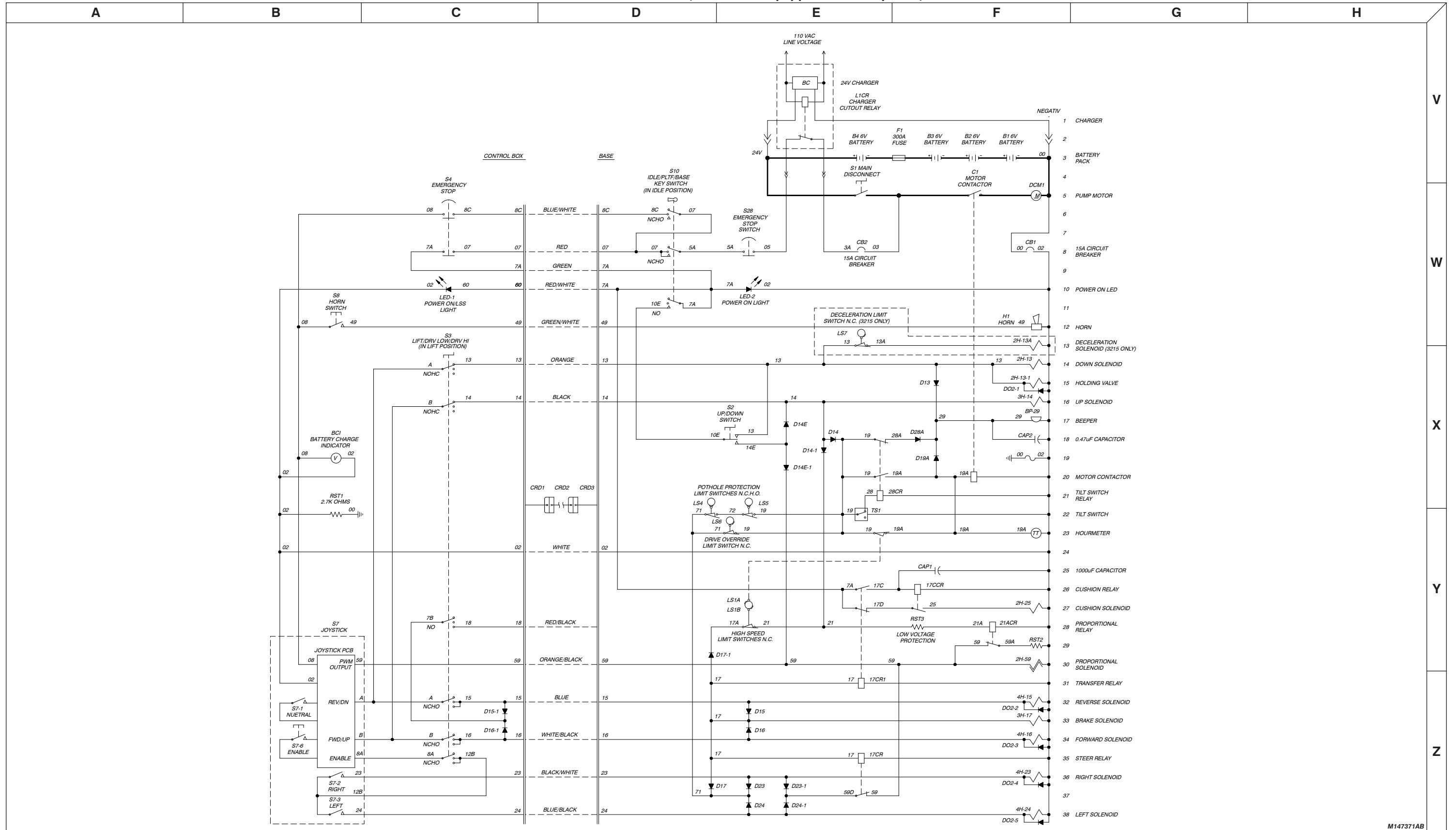

M147371AB

3.22 Electrical Schematic (ANSI/CSA - equipped with all options)

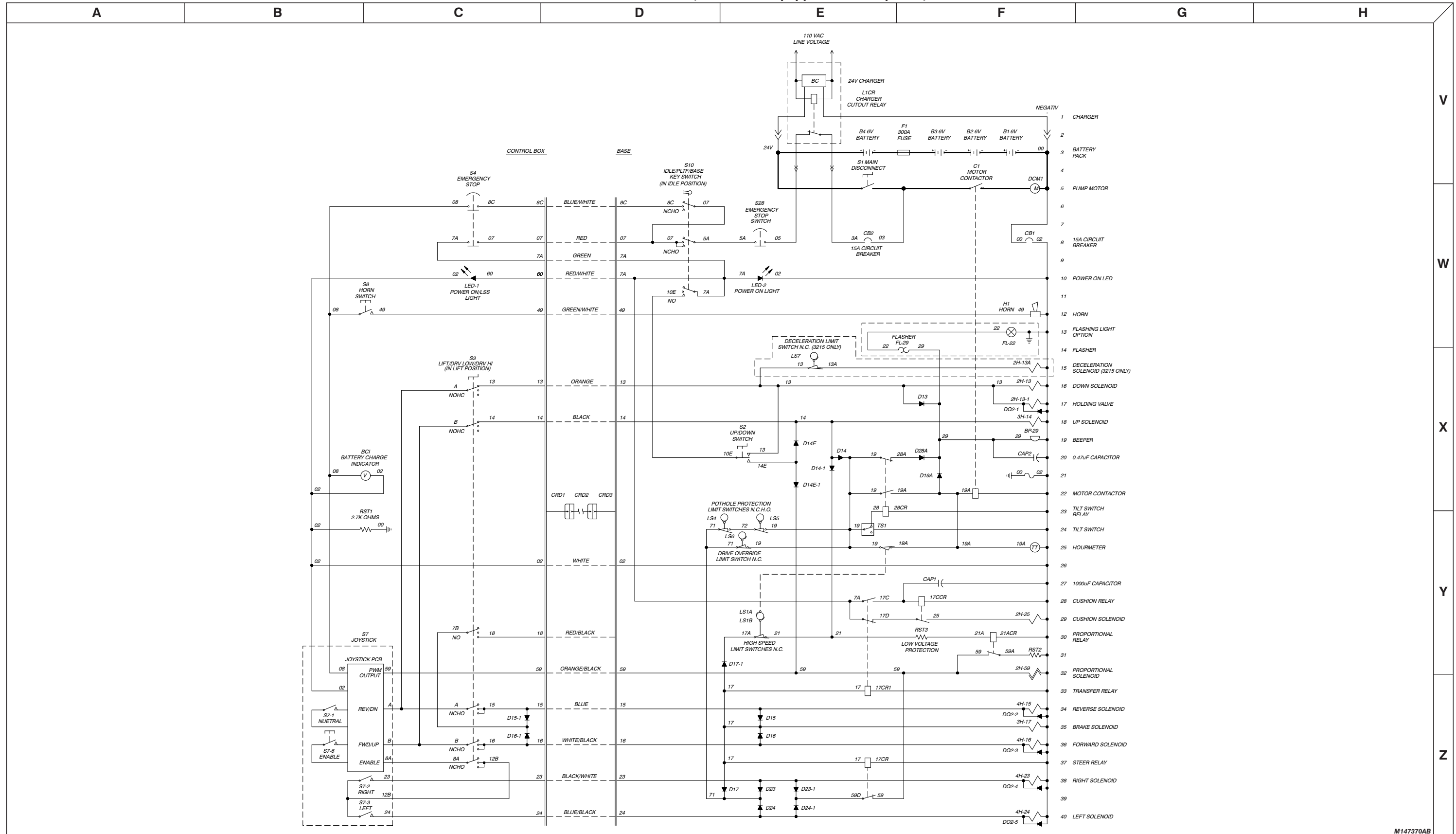

M147370AB

3.23 Electrical Schematic (CE - equipped with all options)

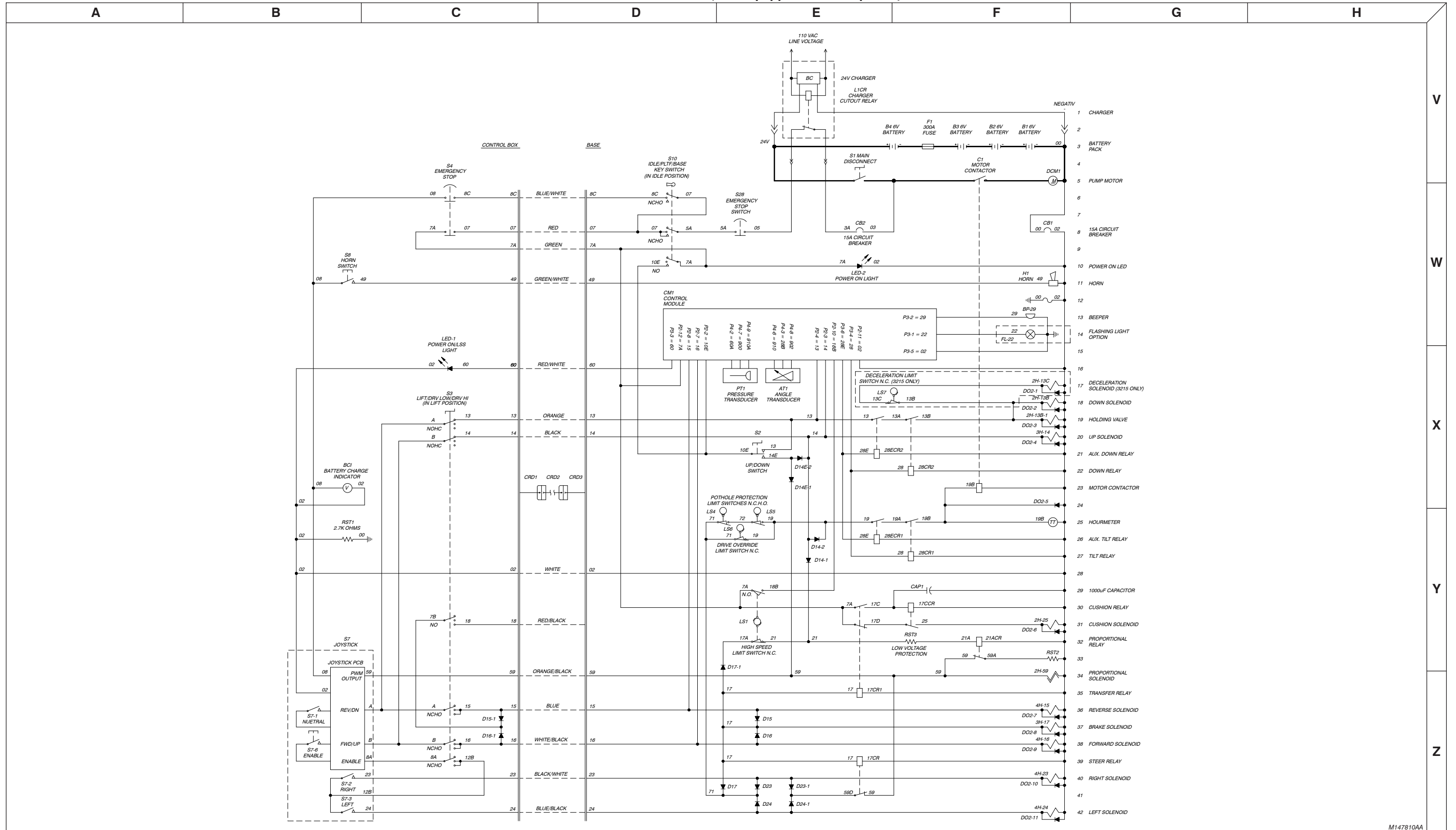

M147810AA

3.24 Electrical Schematic (ANSI/CSA EE Rated - equipped with no options)

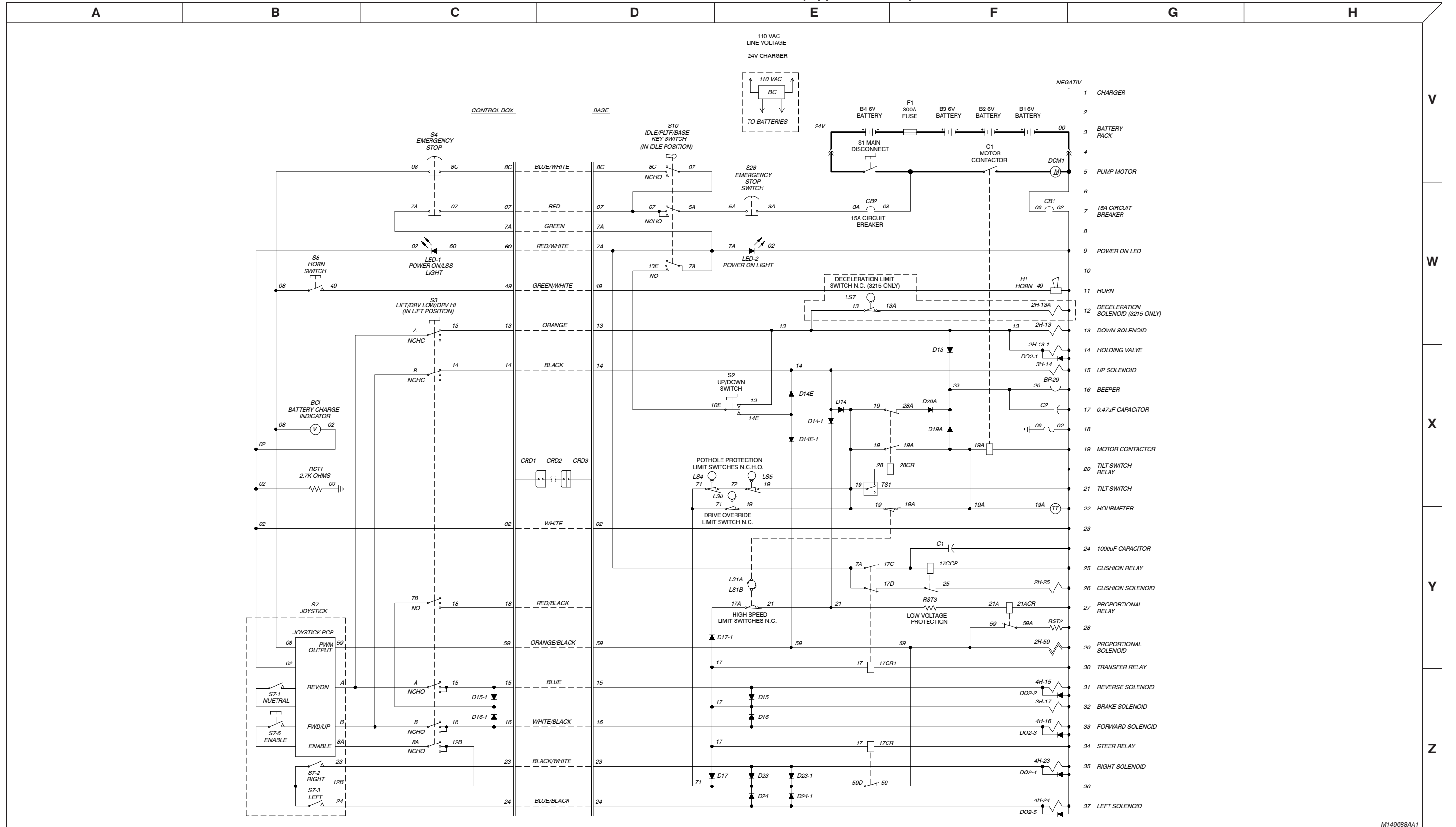

M149688AA1

3.25 Electrical Schematic (ANSI/CSA EE Rated - equipped with all options)

AB

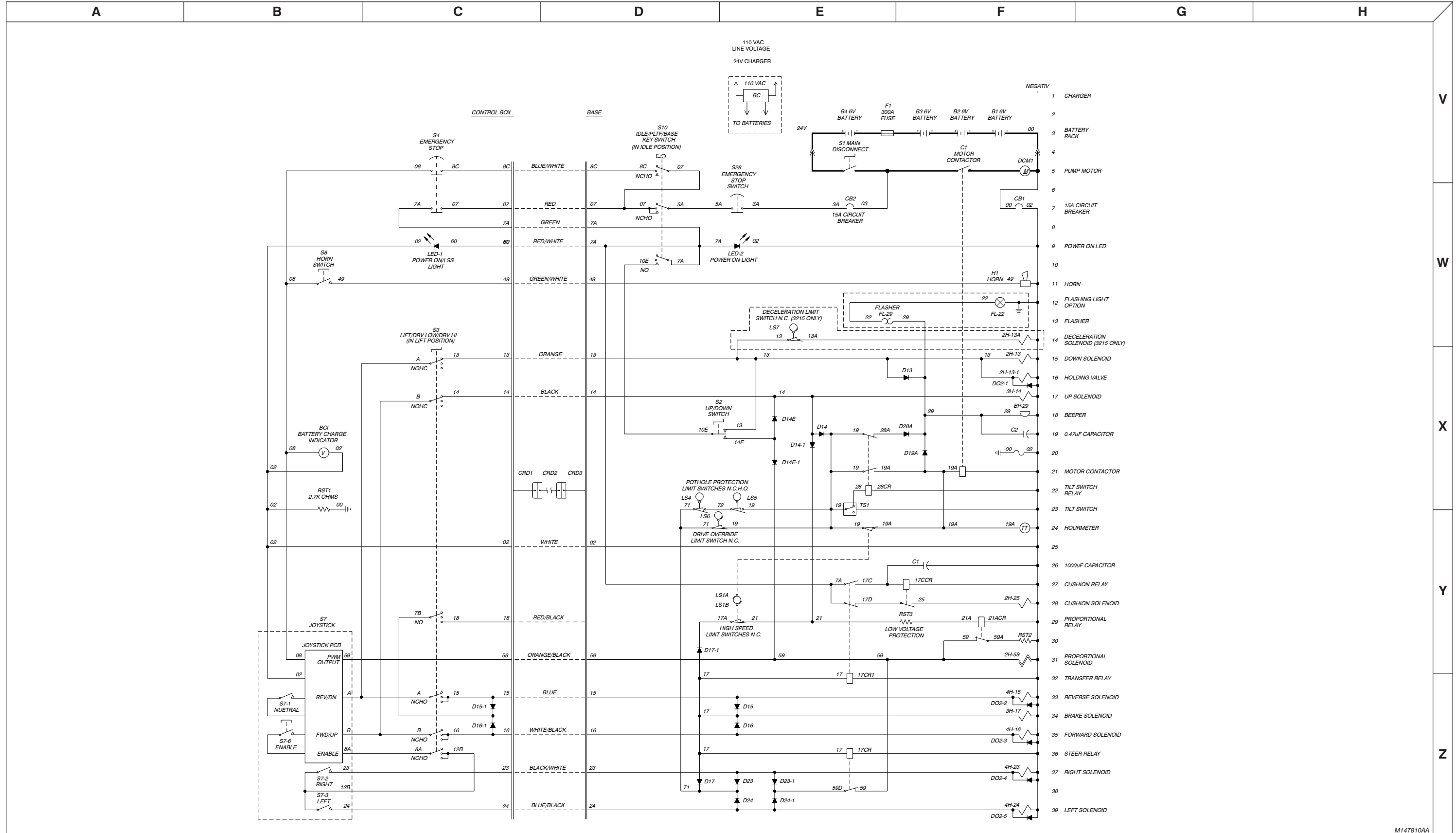

M147810AA

Section 4 TROUBLESHOOTING INFORMATION

Table of Contents

Introduction	3
Electrical System	
4.1-1 All Controls Inoperative.....	4
4.1-2 All Controls Except for Down Function Inoperative	4
4.1-3 All Controls Inoperative From Base Control Console	5
4.1-4 All Controls Inoperative From Platform Control Console	5
4.1-5 No Drive or Up Function from Platform or Base Controls (CE only)	5
4.1-6 No Down or Reverse Only Function from Platform Controls	6
4.1-7 No Up or Forward Only Function from Platform Control Console	6
4.1-8 No Up Function from Platform or Base Control Console.....	6
4.1-9 No Down Function from Platform or Base Control Console (ANSI/CSA only)	6
4.1-10 No Down Function from Platform or Base Control Console (CE only).....	7
4.1-11 No Up Function from Base Control Console.....	7
4.1-12 No Down Function from Base Control Console.....	8
4.1-13 Platform Lowers Slowly from Platform and Base (3215 only).....	8
4.1-14 Platform does not Decelerate when Lowering (3215 only).....	8
4.1-15 Platform Lifts Slowly from Platform and Base Control console	8
4.1-16 Steer Only Inoperative	8
4.1-17 Drive Only Inoperative	8
4.1-18 No Drive or Steer when Platform Fully Lowered	8
4.1-19 No Drive or Steer when Platform Elevated.....	9
4.1-20 Elevated Drive Speed Does Not Activate	9
4.1-21 Work Platform Drives in Slow Speed Only	9
4.1-22 Forward Drive Function Inoperative	9
4.1-23 Reverse Drive Function Inoperative.....	10
4.1-24 Brake will not Release.....	10
4.1-25 Two or more Functions at one time	10
Hydraulic System	
4.2-1 All Functions Inoperative	11
4.2-2 All Functions Sluggish	11
4.2-3 Platform Drifts Down.....	11
4.2-4 Platform Lifts Slowly.....	11
4.2-5 Platform Does Not Lift.....	11
4.2-6 Platform will not Lower.....	12
4.2-7 Platform Lowers Slowly	12
4.2-8 Platform Drives Slow.....	12
4.2-9 Platform will not Drive in Forward or Reverse	12
4.2-10 Brake(s) will not Release	13
4.2-11 Platform does not Steer	13
Load Sensing System	
4.3-1 Flash Code F01: Check HWFS.....	14
4.3-2 Flash Code F02: Not Ground Mode.....	14
4.3-3 Flash Code F03: Not Stopped.....	14
4.3-4 Flash Code F04: Tilted.....	14



Table of Contents (Continued)

4.3-5	Flash Code F05: Bad Height	14
4.3-6	Flash Code F06: Check Elev	14
4.3-7	Flash Code F08: Check Elev	14
4.3-8	Flash Code F09: Bad Height	14
4.3-9	Flash Code F10: Bad Height	14
4.3-10	Flash Code F11: Not Up	14
4.3-11	Flash Code F12: Too Many	15
4.3-12	Flash Code F13: Low Height Range	15
4.3-13	Flash Code F14: Bad Height	15
4.3-14	Flash Code F15: Check Elev	15
4.3-15	Flash Code F16: Low Elev.open	15
4.3-16	Flash Code F17: High Elev.open	15
4.3-17	Flash Code F18: Low Elev.close	15
4.3-18	Flash Code F19: High Elev.close	16
4.3-19	Flash Code F20: Height <> 0%	16
4.3-20	Flash Code F21: Height <> 0%	16
4.3-21	Flash Code F22: Height <> 100%	16
4.3-22	Flash Code F23: Height <> 100%	16
4.3-23	Flash Code F24: Too Many	16
4.3-24	Flash Code F25: Check Elev	16
4.3-25	Flash Code F26: Check Elev	16
4.3-26	Flash Code F27: Bad Height	17
4.3-27	Flash Code F30: Bad Heights	17
4.3-28	Flash Code F31: Reject Curve	17
4.3-29	Flash Code F32: Reject Curve	17
4.3-30	Flash Code F33: Reject Curve	17
4.3-31	Flash Code F34: Reject Curve	17
4.3-32	Flash Code F40: Reject Delta	17
4.3-33	Flash Code F42: Low Pressure	17
4.3-34	Flash Code F43: High Pressure	18
4.3-35	Flash Code F44: Low Pressure	18
4.3-36	Flash Code F45: High Pressure	18
4.3-37	Flash Code F46: Check Elev	18
4.3-38	Flash Code F47: Check Elev	18

Introduction

The following pages contain a table of Troubleshooting Information for locating and correcting most service trouble which can develop. Careful and accurate analysis of the systems listed in the table of Troubleshooting Information will localize the trouble more quickly than any other method. This manual cannot cover all possible troubles and deficiencies that may occur. If a specific trouble is not listed, isolate the major component in which the trouble occurs, isolate whether the problem is electrical or hydraulic, and then isolate and correct the specific problem.

The content of this section is separated into “probable cause” and “remedy.” The information preceded by a number represents the “probable cause.” The following line, noted by a dash represents the “remedy” to the “probable cause” directly above it. See example below for clarification.

1. Probable Cause
 - Remedy

Electrical System

4.1-1 All Controls Inoperative

1. Battery charger plugged into external power source.
 - Disconnect charger cord.
2. Batteries disconnected.
 - Connect batteries.
3. Dirty or loose battery terminals.
 - Clean and tighten connections.
4. Battery charge low.
 - Check each cell with a hydrometer. Reading should be 1.275 (fully charged). Recharge if low reading. Replace if reading difference between cells is 0.050.
5. Main battery cables open or defective.
 - Check continuity. Replace if defective.
6. Fuse F1 defective.
 - Replace fuse.
7. Main battery disconnect switch S1 open or defective.
 - Close switch. Check continuity. Replace if defective.
8. Loose or broken wire #3 from motor contactor C1 to circuit breaker CB2.
 - Check continuity. Replace if defective.
9. Loose or broken wire #3A from circuit breaker CB2 to charger relay L1CR.
 - Check continuity. Replace if defective.
10. Defective or tripped circuit breaker CB2.
 - Reset circuit breaker. Replace if defective.
11. Defective battery charger relay L1CR.
 - Check relay. Replace if defective.
12. Loose or broken wire #5 from charger relay L1CR to base emergency stop switch S28.
 - Check continuity. Replace if defective.
13. Open or defective base emergency stop switch S28.
 - Close switch. Check switch. Replace if defective.
14. Loose or broken wire #5A from base emergency stop switch S28 to base key switch S10.
 - Check continuity. Replace if defective.
15. Open or defective base key switch S10.
 - Select function with switch. Check switch. Replace if defective.
16. Loose or broken wire #00 from pump motor DCM1 to circuit breaker CB1.
 - Check continuity. Replace if defective.
17. Defective or tripped circuit breaker CB1.
 - Reset circuit breaker. Replace if defective.
18. Loose or broken wire #02 from circuit breaker CB1 to base terminal block.
 - Check continuity. Replace if defective.
19. Loose or broken wire #7A from base terminal block to CM1 control module pin P2-12. **(CE only)**
 - Check continuity. Replace if defective.
20. Loose or broken wire #02 from base terminal block to CM1 control module pin P2-11. **(CE only)**
 - Check continuity. Replace if defective.

4.1-2 All Controls Except for Down Function Inoperative

1. Loose or broken wire #59 from base terminal block to proportional valve 2H-59.
 - Check continuity. Replace if defective.
2. Loose or broken wire #02 from base terminal block to proportional valve 2H-59.
 - Check continuity. Replace if defective.
3. Defective proportional valve coil.
 - Check coil for resistance. Reading should be 19 ohms. Replace if defective.

Electrical System (Continued)

4.1-3 All Controls Inoperative From Base Control Console

1. Loose or broken wire #07 from base terminal block to platform emergency stop switch S4.
 - Check continuity. Replace if defective.
2. Open or defective platform emergency stop switch S4.
 - Close switch. Replace if defective.
3. Loose or broken wire #7A from platform emergency stop switch S4 to base terminal block.
 - Check continuity. Replace if defective.
4. Loose or broken wire #7A from base terminal block to base key switch S10.
 - Check continuity. Replace if defective.
5. Open or defective base key switch S10.
 - Close switch. Replace if defective.
6. Loose or broken wire #10E from base key switch S10 to base up/down switch S2.
 - Check continuity. Replace if defective.

4.1-4 All Controls Inoperative From Platform Control Console

1. Loose or broken wire #8C from base key switch S10 to base terminal block.
 - Check continuity. Replace if defective.
2. Loose or broken wire #8C or wire #02 from base terminal block to platform emergency stop switch S4.
 - Check continuity. Replace if defective.
3. Open or defective platform emergency stop switch S4.
 - Close switch. Replace if defective.
4. Loose or broken wire #8 or wire #02 from emergency stop switch S4 to battery charge indicator BCI.
 - Check continuity. Replace if defective.
5. Loose or broken wire #8 or wire #02 from battery charge indicator BC1 to joystick S7.
 - Check continuity. Replace if defective.
6. Defective joystick enable switch S7-6.
 - Check switch. Replace if defective.
7. Defective joystick neutral switch S7-1.
 - Check switch. Replace if defective.
8. Defective joystick S7.
 - Check joystick. Replace if defective.

4.1-5 No Drive or Up Function from Platform or Base Controls (CE only)

1. Defective tilt relay 28CR1 or Aux. tilt relay 28ECR1.
 - Check relay. Replace if defective.
2. Loose or broken wire #02 from base terminal block to tilt relay 28CR1 or Aux. tilt relay 28ECR1.
 - Check continuity. Replace if defective.
3. Loose or broken wire #28 from CM1 control module pin P3-4 to tilt relay 28CR1.
 - Check continuity. Replace if defective.
4. Loose or broken wire #28E from CM1 control module pin P3-6 to Aux. tilt relay 28ECR1.
 - Check continuity. Replace if defective.
5. Loose or broken wire #19 from base terminal block to Aux. tilt relay 28ECR1.
 - Check continuity. Replace if defective.
6. Loose or broken wire #19A from Aux. tilt relay 28ECR1 to tilt relay 28CR1.
 - Check continuity. Replace if defective.

Electrical System (Continued)

7. Loose or broken wire #19B from tilt relay 28CR1 to base terminal block.
 - Check continuity. Replace if defective.
8. Loose or broken wire #19B from base terminal block to motor contactor C1.
 - Check continuity. Replace if defective.

4.1-6 No Down or Reverse Only Function from Platform Controls

1. Loose or broken wire "A" from proportional controller S7 to lift/drive switch S3.
 - Check continuity. Replace if defective.
2. Lift/Drive switch S3 defective.
 - Check switch. Replace if defective.
3. Defective PWM card on joystick S7.
 - Check joystick card. Replace if defective.
4. Loose or broken wire #13 down or #15 reverse from lift/drive switch S3 to base terminal block.
 - Check continuity. Replace if defective.

4.1-7 No Up or Forward Only Function from Platform Control Console

1. Loose or broken wire "B" from proportional controller S7 to lift/drive switch S3.
 - Check continuity. Replace if defective.
2. Lift/Drive switch S3 defective.
 - Check switch. Replace if defective.
3. Defective PWM card on joystick S7.
 - Check joystick card. Replace if defective.
4. Loose or broken wire #14 up or #16 forward from lift/drive switch S3 to base terminal block.
 - Check continuity. Replace if defective.

4.1-8 No Up Function from Platform or Base Control Console

1. Loose or broken wire #14 from base terminal block to up valve coil 3H-14.
 - Check continuity. Replace if defective.
2. Defective up valve coil 3H-14.
 - Check continuity through coil. Replace if defective.
3. Open diode D14-1.
 - Check diode. Replace if defective.
4. Open diode D14 (**ANSI/CSA**) or D14-2 (**CE**).
 - Check diode. Replace if defective.
5. Machine not level. (Above high speed limit switch)
 - Use on level surface.
6. Loose or broken wire #19 from base terminal block to tilt switch TS1 (**ANSI/CSA only**).
 - Check continuity. Replace if defective.
7. Defective tilt switch TS1 (**ANSI/CSA only**).
 - Test tilt switch. Replace if defective.
8. Loose or broken wire #28 from tilt switch TS1 to tilt relay 28CR (**ANSI/CSA only**).
 - Check continuity. Replace if defective.
9. Loose or broken wire #02 from tilt switch TS1 to base terminal strip (**ANSI/CSA only**).
 - Check continuity. Replace if defective.
10. Defective tilt relay 28CR (**ANSI/CSA only**).
 - Check relay. Replace if defective.
11. Loose or broken wire #19A from tilt relay 28CR to pump motor contactor (**ANSI/CSA only**).
 - Check continuity. Replace if defective.

Electrical System (Continued)

12. Open or defective diode D14E-1
 - Check diode. Replace if defective.
13. See 4.1-5 of this section for more troubleshooting information.

4.1-9 No Down Function from Platform or Base Control Console (ANSI/CSA only)

NOTE

Down function is not proportionally controlled.

1. Loose or broken wire #13 from base terminal block to down valve 2H-13 or holding valve 2H-13-1.
 - Check continuity. Replace if defective.
2. Loose or broken wire #02 from base terminal block to down valve 2H-13 or holding valve 2H-13-1.
 - Check continuity. Replace if defective.
3. Defective down valve 2H-13.
 - Check continuity through coil. Replace if defective.
4. Defective lift cylinder holding valve 2H-13-1.
 - Check continuity through coil. Replace if defective.

4.1-10 No Down Function from Platform or Base Control Console (CE only)

NOTE

Down function is not proportionally controlled.

1. Loose or broken wire #13 from base terminal block to CM1 control module pin P2-4.
 - Check continuity. Replace if defective.
2. Defective down relay 28CR2 or Aux. down relay 28ECR2.
 - Check relay. Replace if defective.
3. Loose or broken wire #02 from base terminal block to down relay 28CR2 or Aux. down relay 28ECR2.
 - Check continuity. Replace if defective.
4. Loose or broken wire #13 from base terminal block to Aux. down relay 28ECR2.
 - Check continuity. Replace if defective.
5. Loose or broken wire #13A from Aux. down relay 28ECR2 to down relay 28CR2.
 - Check continuity. Replace if defective.
6. Loose or broken wire # 13B from down relay 28CR2 to down valve 2H-13B or holding valve 2H-13B-1.
 - Check continuity. Replace if defective.
7. Defective down valve 2H-13B.
 - Check continuity through coil. Replace if defective.
8. Defective lift cylinder holding valve 2H-13B-1.
 - Check continuity through coil. Replace if defective.
9. Loose or broken wire #02 from holding valve 2H-13B-1 or down valve 2H-13B to base terminal block.
 - Check continuity. Replace if defective.

4.1-11 No Up Function from Base Control Console

1. Defective up/down switch S2.
 - Check switch. Replace if defective.
2. Loose or broken wire #14E from up/down switch S2 to base terminal switch.
 - Check continuity. Replace if defective.

Electrical System (Continued)

3. Open diode D14E-1.
 - Check diode. Replace if defective.
4. Open diode D14E.
 - Check diode. Replace if defective.

4.1-12 No Down Function from Base Control Console

1. Defective up/down switch S2.
 - Check switch. Replace if defective.
2. Loose or broken wire #13 from up/down switch S2 to base terminal block.
 - Check continuity. Replace if defective.

4.1-13 Platform Lowers Slowly from Platform and Base (3215 only)

1. Deceleration limit switch LS7 stuck, out of adjustment or is defective.
 - Readjust limit switch so it returns to the normally closed position at 14" before completely stowed. Check the limit switch is functioning. Replace if defective.

4.1-14 Platform does not Decelerate when Lowering (3215 only)

1. Deceleration limit switch LS7 out of adjustment.
 - Readjust limit switch so it returns to the normally closed position at 14" before completely stowed. Check the limit switch is functioning. Replace if defective.
2. Loose or broken wire #13A (ANSI/CSA) or #13C (CE) from terminal strip to deceleration valve coil 2H-13A (ANSI/CSA) or 2H-13C (CE).
 - Check continuity. Replace if defective.
3. Loose or broken wire #02 from terminal strip to deceleration valve coil 2H-13A (ANSI/CSA) or 2H-13C (CE).
 - Check continuity. Replace if defective.
4. Defective deceleration valve coil 2H-13A (ANSI/CSA) or 2H-13C (CE).
 - Check coil. Replace if defective.

4.1-15 Platform Lifts Slowly from Platform and Base Control console

1. Open diode D14-1.
 - Check diode. Replace if defective.

4.1-16 Steer Only Inoperative

1. Defective relay 17CR.
 - Check relay. Replace if defective.
2. Loose or broken wire #59D from diodes D23-1 and D24-1 to base terminal block TB1.
 - Check continuity. Replace if defective.
3. Loose or broken wire #59D from 17CR steer relay to base terminal block TB1.
 - Check continuity. Replace if defective.
4. Loose or broken wire #59 from 17CR steer relay to base terminal block TB1.
 - Check continuity. Replace if defective.

4.1-17 Drive Only Inoperative

1. Open diode D17.
 - Check diode. Replace if defective.

Electrical System (Continued)

4.1-18 No Drive or Steer when Platform Fully Lowered

1. Loose or broken wire #71 from base terminal block to drive override limit switch LS6.
 - Check continuity. Replace if defective.
2. Defective drive override switch LS6.
 - Check switch. Replace if defective.
3. Loose or broken wire #19 from drive override limit switch LS6 to base terminal block.
 - Check continuity. Replace if defective.

4.1-19 No Drive or Steer when Platform Elevated

1. Pothole protection bars not fully lowered.
 - Clear obstructions. Repair as needed.
2. Loose or broken wire #71 from base terminal block to pothole protection limit switch LS4.
 - Check continuity. Replace if defective.
3. Defective pothole protection limit switch LS4.
 - Check switch. Replace if defective.
4. Loose or broken wire #72 from pothole protection limit switch LS4 to base terminal block.
 - Check continuity. Replace if defective.
5. Loose or broken wire #72 from base terminal block to pothole protection limit switch LS5.
 - Check continuity. Replace if defective.
6. Defective pothole protection limit switch LS5.
 - Check switch. Replace if defective.
7. Loose or broken wire #19 from pothole protection limit switch LS5 to base terminal block.
 - Check continuity. Replace if defective.

4.1-20 Elevated Drive Speed Does Not Activate

1. Loose or broken wire #59 from base terminal strip proportional relay 21ACR.
 - Check continuity. Replace if defective.
1. Loose or broken wire #59A from proportional relay 21ACR to resistor RST2.
 - Check continuity. Replace if defective.
2. Resistor RST2 open.
 - Check resistor ohms, it should be 30 ohms. Replace if defective.
3. Loose or broken wire #02 from resistor RST2 to base terminal block.
 - Check continuity. Replace if defective.
4. Proportional relay 21ACR defective.
 - Check relay, replace if defective.

4.1-21 Work Platform Drives in Slow Speed Only

1. Open diode D17-1.
 - Check diode. Replace if defective.
2. Loose or broken wire #17A from base terminal block to high speed limit switch LS1B.
 - Check continuity. Replace if defective.
3. Open or defective high speed limit switch LS1B.
 - Check switch. Replace if defective.
4. Loose or broken wire #21 from high speed limit switch LS1B to low voltage protection resistor RST3.
 - Check continuity. Replace if defective.
5. Defective low voltage protection resistor RST3.
 - Check resistor. Replace if defective.
6. Loose or broken wire #21A from low voltage protection resistor RST3 to proportional relay 21ACR.
 - Check continuity. Replace if defective.

Electrical System (Continued)

7. Proportional relay 21ACR defective.
 - Check relay, replace if defective.
8. Loose or broken wire #2 from proportional relay 21ACR to base terminal block.
 - Check continuity. Replace if defective.
9. Proportional controller S7 out of adjustment.
 - Adjust controller. Refer to Section 5, Joystick Adjusting Procedure.

4.1-22 Forward Drive Function Inoperative

1. Loose or broken wire #16 from lift/drive switch S3 to base terminal block.
 - Check continuity. Replace if defective.
2. Loose or broken wire #16 from base terminal block to forward drive valve coil 4H-16.
 - Check continuity. Replace if defective.
3. Forward drive valve coil 4H-16 defective.
 - Check continuity through coil. Replace if defective.
4. Loose or broken wire #02 from forward drive valve coil 4H-16 to base terminal block.
 - Check continuity. Replace if defective.
5. Open diode D16.
 - Check diode. Replace if defective.

4.1-23 Reverse Drive Function Inoperative

1. Loose or broken wire #15 from lift/drive switch S3 to base terminal block.
 - Check continuity. Replace if defective.
2. Loose or broken wire #15 from base terminal block to reverse drive valve coil 4H-15.
 - Check continuity. Replace if defective.
3. Reverse drive valve coil 4H-15 defective.
 - Check continuity through coil. Replace if defective.
4. Loose or broken wire #02 from reverse drive valve coil 4H-15 to base terminal block.
 - Check continuity. Replace if defective.
5. Open diode D15.
 - Check diode. Replace if defective.

4.1-24 Brake will not Release

1. Diode D-16 forward or D-15 reverse is shorted or open.
 - Check diode. Replace if defective.
2. Loose or broken wire #17 from base terminal strip to brake coil 3H-17.
 - Check continuity. Replace if defective.
3. Brake valve coil 3H-17 defective.
 - Check continuity through coil. Replace if defective.
4. Loose or broken wire #02 from brake valve coil 3H-17 to base terminal block.
 - Check continuity. Replace if defective.

4.1-25 Two or more Functions at one time

1. Shorted diode.
 - Check continuity of all diodes. Replace if defective.

Hydraulic System

4.2-1 All Functions Inoperative

1. Proportional valve 2H-59 defective or is sticking.
 - Check valve. Replace if defective.
2. Compensator portion of proportional valve defective or is sticking.
 - Check valve. Replace if defective.
3. Pump P1 defective.
 - Check pump. Replace if defective.

4.2-2 All Functions Sluggish

1. System relief valve R1 defective or not adjusted properly.
 - Adjust valve. Replace if defective.
2. Hydraulic pump P1 worn.
 - Check pump. Replace if defective.

4.2-3 Platform Drifts Down

1. Defective lift cylinder gland seal.
 - Check for hydraulic oil leaking from the gland seal. Rebuild cylinder. Replace if damaged.
2. Combination of: Defective holding valve 2H-13-1 and either defective lowering valve 2H-13 or relief valve R2 or manual lowering valve V1. **(ANSI/CSA only)**
 - Check valves. Replace if defective.Combination of: Defective holding valve 2H-13B-1 and either defective lowering valve 2H-13B or relief valve R2 or manual lowering valve V1. **(CE only)**
 - Check valves. Replace if defective.
3. Defective o-ring between lift cylinder and holding valve manifold block or loose bolts holding the manifold.
 - Check for hydraulic oil leaking from between cylinder and manifold. Tighten bolts on manifold or replace o-ring. Replace manifold if damaged.

4.2-4 Platform Lifts Slowly

1. Open or leaking manual lowering valve V1.
 - Close valve. Replace if defective.
2. Lift relief valve R2 defective or not adjusted correctly.
 - Adjust valve. Replace if defective.
3. Open manual override on holding valve 2H-13-1 **(ANSI/CSA)** or 2H-13B-1 **(CE)**.
 - Depress and turn manual override clockwise to close. Replace if defective.
4. Stuck or defective deceleration valve 2H-13A **(ANSI/CSA)** or 2H-13C **(CE)**. **(3215 only)**
 - Check valve. Replace if defective.

4.2-5 Platform Does Not Lift

1. Open manual lowering valve V1.
 - Close valve. Replace if defective.
2. Hydraulic oil level too low.
 - Fully lower the platform. Fill hydraulic tank with recommended fluid to appropriate level.
3. Platform weight excessive.
 - Reduce platform load to maximum capacity.
4. Up valve 3H-14 defective or is sticking.
 - Check valve. Replace if defective.
5. Plugged deceleration valve 2H-13A **(ANSI/CSA)** or 2H-13C **(CE)**. **(3215 only)**
 - Clear obstruction from valve. Replace if defective.

Hydraulic System (Continued)

4.2-6 Platform will not Lower

NOTE

Down function is not proportionally controlled.

1. Lowering valve 2H-13 (ANSI/CSA) or 2H-13B (CE) defective or is sticking.
 - Clean valve. Replace if defective.
2. Defective holding valve 2H-13-1 (ANSI/CSA) or 2H-13B-1 (CE).
 - Clean valve. Replace if defective.
3. Lowering orifice O2 (3219 only) plugged or contaminated.
 - Clear debris. Replace Orifice. Replace if defective.
4. Emergency lowering orifice O6 plugged or contaminated.
 - Clear debris. Replace Orifice. Replace if defective.
5. Plugged deceleration valve 2H-13A (ANSI/CSA) or 2H-13C (CE).
 - Clear obstruction from valve. Replace if defective.

4.2-7 Platform Lowers Slowly

1. Stuck or defective deceleration valve 2H-13A (ANSI/CSA) or 2H-13C (CE).
 - Check valve. Replace if defective.

4.2-8 Platform Drives Slow

1. Free-wheeling valve V2 open or defective.
 - Close valve. Replace if defective.
2. Drive motor M1 or M2 defective.
 - Check motors. Replace if defective.
3. Cushion valve 2H-25 is stuck or defective.
 - Check valve. Replace if defective.

4.2-9 Platform will not Drive in Forward or Reverse

1. Open free-wheeling valve V2.
 - Close Valve. Replace if defective.
2. Forward drive valve 4H-16 or reverse drive valve 4H-15 defective or is sticking.
 - Clean Valve. Replace if defective.
3. Counterbalance valve CB1 defective or is plugged.
 - Clean Valve. Replace if defective.

Hydraulic System (Continued)

4.2-10 Brake(s) will not Release

1. Brake valve 3H-17 defective or is sticking.
 - Clean valve. Replace if defective.
2. Brake orifice 04 plugged.
 - Remove orifice. Clean and reinstall.
3. Brake cylinder C4 defective.
 - Rebuild cylinder. Replace if damaged.

4.2-11 Platform does not Steer

1. Right steer valve 4H-23 or left steer valve 4H-24 defective or sticking.
 - Clean valve. Replace if defective.
2. Steer cylinder C3 seals leaking.
 - Rebuild cylinder(s). Replace if damaged.
3. Mechanical binding in king pins.
 - Check for binding. Repair as needed.
4. Orifices 05 plugged.
 - Clean Orifices, and reinstall.

Load Sensing System - CE

4.3-1 Flash Code F01: Check HWFS

1. This message is given if the GP102 startup tests have not completed.
 - Check [HELP](#) message for more information.

4.3-2 Flash Code F02: Not Ground Mode

1. This message is given if the machine is not in ground mode (P2-2 must be high).
 - Calibration can only be carried out in ground mode.

4.3-3 Flash Code F03: Not Stopped

1. This message is given if the machine is not in ground mode (P2-2 must be high).
 - Check [DIAGNOSTICS / SWITCHES](#) to see which function switch is closed.

4.3-4 Flash Code F04: Tilted

1. This message is given if the machine is tilted.
 - Calibration must be carried out with the machine level. If the machine is level, use the [SETUPS / TILT SETUPS](#) to set the GP102 level.

4.3-5 Flash Code F05: Bad Height

1. This message is given if the height sensor output (P4-3) is out of range at the start of calibration.
 - The height sensor output must be between 1.0V and 4.0V. Check [DIAGNOSTICS / SENSORS](#) to see the output. A reading of 0V or 5V is probably due to a wiring problem.

4.3-6 Flash Code F06: Check Elev

1. This message is given if the elevation switch (P2-10) is open at the start of calibration, when the operator has confirmed the "PLATFORM DOWN?" question.
 - If the platform is down, check the elevation switch wiring.

4.3-7 Flash Code F08: Check Elev

1. This message is given if the elevation switch (P2-10) is closed at the end of the DYNAMIC lift, when the platform should be fully raised.
 - This message would occur if the UP switch was accidentally opened near the start of the DYNAMIC lift. If the platform is fully raised, check the elevation switch wiring.

4.3-8 Flash Code F09: Bad Height

1. This message is given if the height sensor output (P4-3) is out of range at the start of the DYNAMIC lift.
 - The height sensor output must be between 1.0V and 4.0V. Check [DIAGNOSTICS / SENSORS](#) to see the output.

4.3-9 Flash Code F10: Bad Height

1. This message is given if the height sensor output (P4-3) is out of range at the end of the DYNAMIC lift.
 - The height sensor output must be between 1.0V and 4.0V. Check [DIAGNOSTICS / SENSORS](#) to see the output. A reading of 0V or 5V is probably due to a wiring problem.

4.3-10 Flash Code F11: Not Up

1. This message occurs at the start of the DYNAMIC lift if the operator selects a function other than UP.
 - Select the UP function.

Load Sensing System - CE

4.3-11 Flash Code F12: Too Many

1. This message occurs if the DYNAMIC lift takes too long. This message could occur if the UP switch was not released at the end of the dynamic lift.
 - If the machine takes more than two minutes to lift, the GP102 may need modification to avoid this problem.

4.3-12 Flash Code F13: Low Height Range

1. This message occurs at the end of the DYNAMIC lift if the height sensor output did not change sufficiently to give a reasonably accurate platform height estimate.

This message could occur if the UP switch was accidentally opened too early (when the platform is not fully raised).

This message would occur if the UP switch was accidentally opened near the start of the DYNAMIC lift.

- If the platform is fully raised, check the elevation switch wiring.

4.3-13 Flash Code F14: Bad Height

1. This message occurs if the height sensor output (P4-3) is out of range during the DYNAMIC lift.
 - The height sensor output must be between 1.0V and 4.0V. Check DIAGNOSTICS / SENSORS to see the output. A reading of 0V or 5V is probably due to a wiring problem.

4.3-14 Flash Code F15: Check Elev

1. This message is given if the elevation switch (P2-10) is open when the platform has been fully lowered after the DYNAMIC lift.

This message would occur if the DOWN switch was accidentally opened before the platform was fully lowered.

- If the platform is fully lowered, check the elevation switch.

4.3-15 Flash Code F16: Low Elev.open

1. This message is given if the elevation switch (P2-10) opened during lift at a too low height (below 5%).
 - If it opens below 5%, the pressure is probably too unpredictable to allow reliable detection of an overloaded platform when initially raised. Check CALIBRATIONS / HEIGHT CALS; the "ElevUp" value shows the recorded height where the switch opened.

4.3-16 Flash Code F17: High Elev.open

1. This message is given if the elevation switch (P2-10) opened during lift at a too high height (above 25%).
 - If it opens above 25%, the platform is too high when the overloaded platform is detected! Check CALIBRATIONS / HEIGHT CALS; the "ElevUp" value shows the recorded height where the switch opened.

4.3-17 Flash Code F18: Low Elev.close

1. This message is given if the elevation switch (P2-10) closed during lower at a too low height (below 5%).
 - If it closes below 5%, height sensor fault detection is compromised. Check CALIBRATIONS / HEIGHT CALS; the "ElevDown" value shows the recorded height where the switch opened.

Load Sensing System - CE (Continued)

4.3-18 Flash Code F19: High Elev.close

1. This message is given if the elevation switch (P2-10) closed during lower at a too high height (above 25%).
 - When the switch is closed, overload detection is normally disabled but if the switch closes above 25%, the platform is too high to allow disabled overload. Check CALIBRATIONS / HEIGHT CALS; the "ElevUp" value shows the recorded height where the switch opened.

4.3-19 Flash Code F20: Height<>0%

1. This message occurs if the platform height is not 0% after the platform has been fully lowered during either STATIC lift
 - The platform must return to the same height each time it is fully lowered.
 - Check DIAGNOSTICS / SYSTEM to check the height.

4.3-20 Flash Code F21:Height<>0%

1. This message occurs if the platform height is not 0% before the platform is raised during either STATIC lift.
 - The platform must be at 0% height when it is fully lowered. Check DIAGNOSTICS / SYSTEM to check the height.

4.3-21 Flash Code F22:Height<>100%

1. This message occurs if the platform height is not 100% after the platform has been fully raised during either STATIC lift.
 - The platform must return to the same height each time it is fully raised. Check DIAGNOSTICS / SYSTEM to check the height.

4.3-22 Flash Code F23:Height<>100%

1. This message occurs if the platform height is not 100% before the platform is lowered during either STATIC lift.
 - The platform must be at 100% height when it is fully raised. Check DIAGNOSTICS / SYSTEM to check the height.

4.3-23 Flash Code F24:Too Many

1. This message occurs if too many static measurements are taken during either STATIC lift or lower.
 - It is likely that there is a problem with the lift cylinder pressure; the GP102 should only need about 10 measurements for most vehicles. The SETUPS / HEIGHT SETUPS / MIN LIFT time could be increased to force a longer time between static measurements, but this should not be necessary.

4.3-24 Flash Code F25:Check Elev

1. This message indicates a problem with the elevation switch (P2-10) during the STATIC phases.
 - The switch is either staying closed to a higher height, or staying open to a lower height, than that recorded during the DYNAMIC phase.

4.3-25 Flash Code F26:Check Elev

1. This message indicates a problem with the elevation switch (P2-10) during the STATIC phases.
 - The switch is opening or closing at a different height than that recorded during the DYNAMIC phase.

Load Sensing System - CE (Continued)

4.3-26 Flash Code F27:Bad Height

1. This message indicates a problem with the height sensor output (P4-3) during the STATIC phases.
 - The height sensor output must be between 1.0V and 4.0V at all times. Check [DIAGNOSTICS / SENSORS](#) to see the output. A reading of 0V or 5V is probably due to a wiring problem.

4.3-27 Flash Code F30:Bad Heights

1. This message indicates that the recorded heights are not increasing during either STATIC lift, or are not decreasing during either STATIC lower.
 - It may be possible to cause this problem by repeatedly opening and closing the UP or DOWN switch during the STATIC phases.

4.3-28 Flash Code F31:Reject Curve

1. The DYNAMIC pressure curve is unacceptable.
 - An initial pressure peak when the platform lifted cannot be found between 0% and 15% height. Check the pressure sensor and lift cylinder hydraulics.

4.3-29 Flash Code F32:Reject Curve

1. The DYNAMIC pressure curve is unacceptable.
 - There should be a lowest pressure about halfway through the lift (ie: near 50% height); the lowest pressure measured is at too low a height. Check the pressure sensor and lift cylinder hydraulics.

4.3-30 Flash Code F33:Reject Curve

1. The DYNAMIC pressure curve is unacceptable.
 - There should be a lowest pressure about halfway through the lift (ie: near 50% height); the lowest pressure measured is at too high a height. Check the pressure sensor and lift cylinder hydraulics.

4.3-31 Flash Code F34:Reject Curve

1. The DYNAMIC pressure curve is unacceptable.
 - There is not enough difference between the initial pressure peak and the minimum pressure. Check the pressure sensor and lift cylinder hydraulics.

4.3-32 Flash Code F40:Reject Delta

1. This message indicates that there is not enough difference between the loaded & empty pressure.

This message could also occur if the wrong pressure sensor was fitted (eg: a 5000psi sensor when a 2000psi one is needed)

This message could occur if the platform were not properly loaded during the STATIC LOADED phase, or if the platform were not properly empty during the STATIC EMPTY phase.

- Check [CALIBRATIONS / HEIGHT CALS](#); the "Height" indicates the first height at which there was insufficient difference and the "Up" and "Down" values show the loaded pressure (first) and the difference between loaded and empty pressure (second).

Load Sensing System - CE (Continued)

4.3-33 Flash Code F42:Low Pressure

1. This message indicates that the pressure is too low (0.5V or less) when the elevation switch opens during the DYNAMIC lift.

This message would occur if the pressure sensor was disconnected, or if there were some other wiring error.

- [Check DIAGNOSTICS / SENSORS to check the pressure.](#)

4.3-34 Flash Code F43:High Pressure

1. This message indicates that the pressure is too high (4.5V or more) when the elevation switch opens during the DYNAMIC lift.

This message would occur if the pressure sensor was disconnected, or if there were some other wiring error.

- [Check DIAGNOSTICS / SENSORS to check the pressure.](#)

4.3-35 Flash Code F44:Low Pressure

1. This message indicates that the pressure is too low (0.5V or less) at a STATIC measurement point.

This message would occur if the pressure sensor was disconnected, or if there were some other wiring error.

- [Check DIAGNOSTICS / SENSORS to check the pressure.](#)

4.3-36 Flash Code F45:High Pressure

1. This message indicates that the pressure is too high (4.5V or more) at a STATIC measurement point.

This message would occur if the wrong pressure sensor was fitted, or if there were some other wiring error.

- [Check DIAGNOSTICS / SENSORS to check the pressure.](#)

4.3-37 Flash Code F46:Check Elev

1. This message indicates that the elevation switch opened more than once during the DYNAMIC lift.

4.3-38 Flash Code F47:Check Elev

1. This message indicates that the elevation switch closed more than once during the DYNAMIC lower.

Section 5 PROCEDURES

List of Procedures

Service and Maintenance

General.....	3
Safety and Workmanship.....	3

Platform

5.1-1 OEM Controller Electronics Information	3
5.1-2 OEM Controller Troubleshooting	4
5.1-3 OEM Controller switch wiring.....	5

Base

5.2-1 System Relief Pressure Adjustment.....	6
5.2-2 Lift Pressure Adjustment	6
5.2-3 Electronic Tilt Switch Setup Procedure.....	7
Tilt Switch Replacement.....	7
Reprogramming Existing Tilt Switch	9
Test and Verify Tilt Circuit	10

Load Sensing System - CE

5.3-1 Control Module Pin Reference Chart.....	11
5.3-2 LED Error Codes - Quick Reference Chart	12
5.3-3 LED Error Codes - Code Breakdown Chart.....	13
5.3-4 Hand Held Calibration/Diagnostic Tool Key Functions.....	15
5.3-5 Control Module Load Calibration - Code Messages & Definitions.....	16
5.3-6 Control Module Load Calibration Procedure	20
5.3-7 Curve/Group Codes Chart	24



General

The following information is provided to assist you in the use and application of servicing and maintenance procedures contained in this chapter.

Safety and Workmanship

Your safety, and that of others, is the first consideration when engaging in the maintenance of equipment. Always be conscious of weight. Never attempt to move heavy parts without the aid of a mechanical device. Do not allow heavy objects to rest in an unstable position. When raising a portion of the equipment, ensure that adequate support is provided.

Platform**5.1-1 OEM Controller Electronics Information****Flow Control**

Single coil or solenoid for single direction. The coil has two connections; one is wired to the P.C. Board (A) terminal and the other is wired to (-), or the negative side of the supply voltage. Switches to control directional valves may be provided on the controller.

Adjustment Procedures

Adjustments are made by turning a trimpot adjustment screw. The trimpots are multi-turn, end to end-devices. It may be necessary to turn the adjustment screw several turns to observe a change in output.

Clockwise (CW) adjustment of the trimpot increases the output.

Counter-clockwise (CCW) adjustment of the trimpot decreases the output.

Adjustments affect output current, voltage or percentage of duty cycle to the coil. The minimum and maximum output is preset at the factory. However, for optimum performance, they must be adjusted while the equipment is operating.

Although the following adjustments affect the current/voltage or percentage of duty cycle, the best way to adjust the function is to observe the response or speed of the function. The following adjustments affect function response, or speed. There may be some interaction between adjustments, making it necessary to repeat the adjustment in order to achieve the desired response.

“Threshold” Adjustments

Adjusts the initial current flow or duty cycle, affecting the function response or speed when the handle is first moved from the off position. Deflect the handle slowly to the position where the controller first turns on. Adjust the threshold trimpot screw to the point where the controlled function just starts to move, then turn the trimpot screw one, full turn in the counterclockwise direction. This adjustment should be done first.

“Maxout” Adjustments

Adjusts the full stroke current or duty cycle affecting the maximum function response, or speed when the handle is deflected to its full travel. Fully deflect the handle, and adjust the maxout trimpot for maximum desired function response or speed. To obtain proportional resolution, it is important that the function starts to slow down as soon as the handle is moved back from the fully deflected position.

The ideal adjustment occurs when the function just begins to move when the handle is deflected, and the output increases until it reaches its maximum desired response or speed at the end of handle travel.

5.1-2 OEM Controller Troubleshooting

Problem

1. The function will not operate when the handle is moved. The LEDs do not light
 - A. Check that voltage is present at the positive (+) input terminal.
 - B. Check that ground is connected to the negative (-) terminal.
 - C. If there is an in-line fuse, check to see if it is good.
 - D. Check the controller on/off switch and the connectors. Voltage should be present at the (X) terminal when the controller is turned on.
 - E. Check that valve wiring is not shorted to ground. The LEDs will not light.
 - F. Check that valve wiring is not open. The LEDs will light, but the intensity will not vary.
 - G. Check trimpot settings. Fully "CCW" turns output off, "CW" turns output fully on.
2. The function jumps or lurches when turned on.
 - A. Perform "Threshold" adjustment procedures.
3. The function reaches maximum speed before the handle is fully deflected,
 - A. Perform "Maxout" adjustment procedures.
4. The function speed remains constant regardless of the degree of handle deflection.
 - A. Perform "Maxout" adjustment procedures.

IRS Option

1. Function speed reacts too slowly or too quickly in relation to handle deflection.
 - A. Check "IRS" (Ramp) trimpot adjustment. "CW" increases ramp time, "CCW" decreases ramp time.

Integrated Ramp System (IRS)

Provides smooth function response ,when reacting to an abrupt change in handle deflection. "CW" rotation of the trimpot increases ramp time and slows the response time. "CCW" decreases ramp time and increases the response time. To increase the ramp time, turn the adjusting screw "CW" a few turns, then move the controller handle abruptly. Continue to adjust until a smooth response is observed. Most controllers have on/off contacts which remove power from the P.C. Board when the handle is returned to the off position. When the handle is abruptly returned to neutral, the output will not ramp down, and the function will stop.

Ramp Thru Off

The P.C. Board should be adjusted as outlined in the IRS adjustment procedure. If the handle is abruptly returned to neutral (OFF) the output will ramp down to off. Ramp time is factory set to 2 seconds, unless otherwise specified.

NOTE

Trim pots should be sealed with nail polish or enamel based paint.



WARNING

Do not use RTV silicone.

5.1-3 OEM Controller switch wiring

WIRE CHART		
COLOR	FROM	TO
WHT/RED	STEER LEFT	PIN #1
WHT/GRN	STEER COMMON	PIN #2
WHT	STEER RIGHT	PIN #3
YEL	FORWARD/UP	PIN #4
WHT/BLK	+24V INPUT	PIN #5
GRY	REVERSE/DOWN	PIN #6
BLU	PWM OUT (A)	PIN #7
BLK	GROUND (-)	PIN #8
WHT/BLU	ENABLE OUT	PIN #9

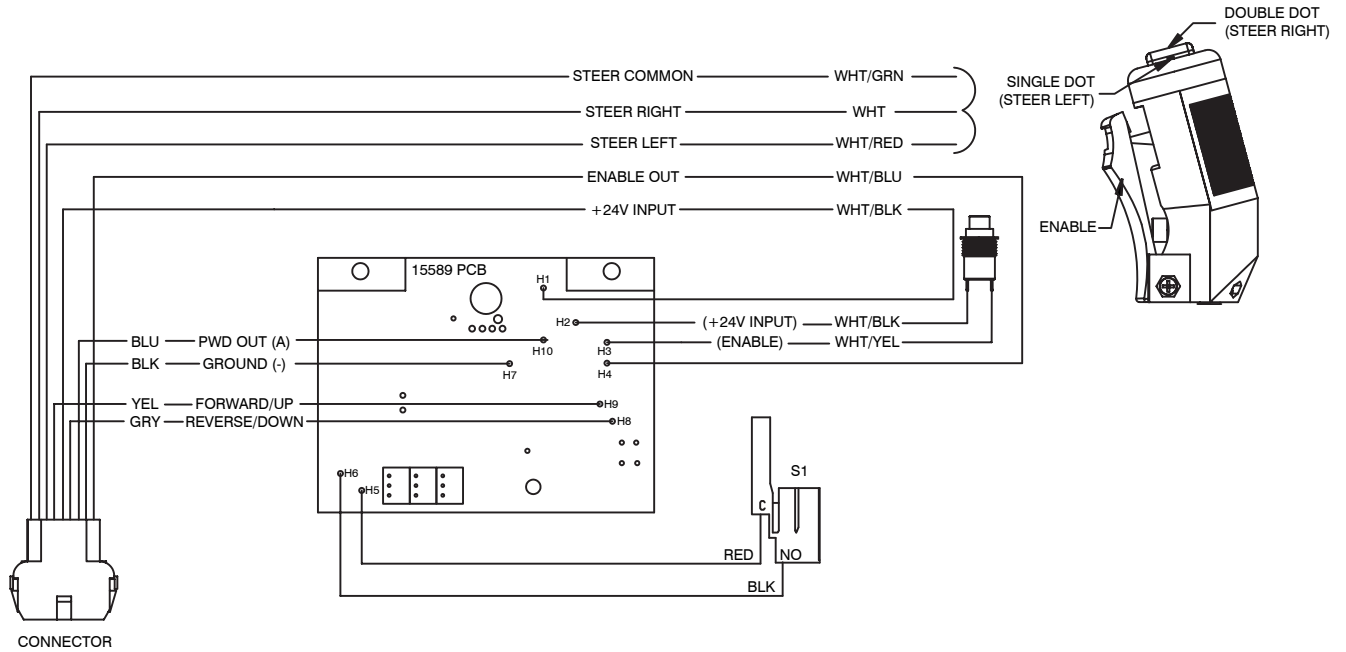

Base**5.2-1 System Relief Pressure Adjustment**

1. Locate the system pressure quick disconnect port on the main manifold.
2. Install a calibrated 5000 psi gauge to the system pressure quick disconnect port.
3. Remove the platform control console the guardrail and disconnect from the main control cable.
4. Locate the main control cable plug at the rear of the aerial platform.
5. Disconnect the main cable and connect the platform control console into the plug.
6. At the main manifold, loosen the locknut on the system relief valve R1.
7. Select drive with the lift/drive select switch on the platform control console.
8. Engaged steer right and hold.
9. Observe reading on gauge. Adjust the R1 system relief value listed on the serial number plate. Turning the stem on the relief valve clockwise will increase pressure. Turning the stem counterclockwise will decrease pressure.
10. Release steer switch and tighten the locknut.
11. Remove the gauge from system pressure test port.

5.2-2 Lift Pressure Adjustment**NOTE**

Adequate area to raise the platform to full height is required for the following steps.

1. Locate the lift pressure test port on the main manifold.
2. Install a calibrated 3000 psi gauge to the lift pressure quick disconnect port.
3. At the main manifold, loosen the locknut on the lift relief valve R2.
4. Close the manual lowering valve. Use the lift switch at the base control console to raise the platform to full height and hold the lift up switch on.
5. Observe the reading on the gauge. Adjust the R2 relief valve to the value listed on the serial number plate. Turning the stem of the relief valve clockwise will increase pressure. Turning the stem counterclockwise will decrease pressure.
6. Remove the gauge from lift pressure test port.

NOTE



Pressure setting may vary as aerial platform components wear. The lift pressure should be set for rated load only.

5.2-3 Electronic Tilt Switch Setup Procedure

The following information is supplied for replacement or reprogramming of the electronic tilt switch. Also included are test and verification instructions. Follow the appropriate procedures below.

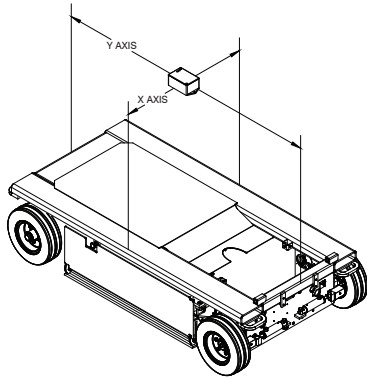
Tilt Switch Replacement



1. Ensure aerial platform is parked on a firm level surface.
2. Chock or block wheels to keep the aerial platform from rolling forward or backward.
3. Lower/Raise the platform and secure the scissors using the maintenance bar. (Refer to Operating manual for Maintenance Support Procedure)
4. Push in “” emergency stop buttons and turn main disconnect switch to “” off position.
5. Remove any covers to locate and view the tilt switch.
6. Disconnect tilt switch from 4 pin connector.
7. Remove old tilt switch from mount.

NOTE

Ensure part number of old and new tilt switch are the same.

8. Install new switch to mount (in the same orientation as the old switch) and connect switch plug to 4 pin connector.

NOTE

The tilt circuit is only powered when activating a function.

9. Disconnect all wires #02 from motor contactor.
10. Install jumper wire between #7 and #19 to terminal strip.
11. Turn main disconnect switch to “” ON position.
12. Verify switch is powered. (Red or green LED will be continually blinking)

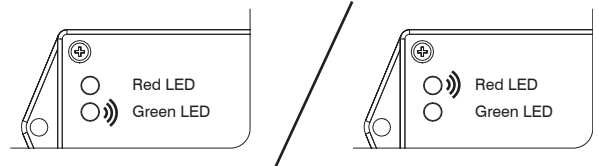

13. Program the Tilt Switch

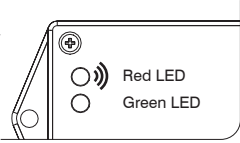
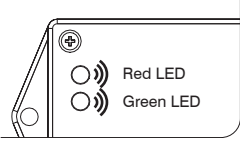
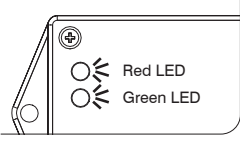
- a. Press and release the set up button 3 times.
- b. Observe program delay / stabilization time. (Only the red LED will blink for 4 seconds) 
- c. Both LEDs will flash for 1 second. **Results:** The switch is learning the new zero position. 
- d. Both LEDs will turn on solid for 1 second. **Results:** The new zero position has been learned. 
- e. The green LED will flash and then the red LED will turn on solid for 2 seconds.

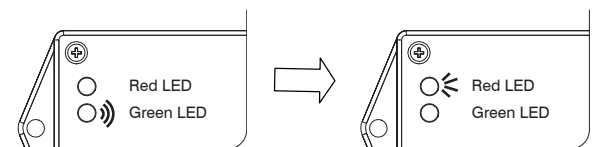

Results: The switch is verifying the new zero position.

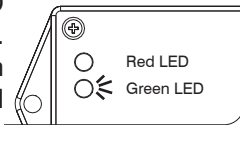
- f. The green LED will turn on solid. **Results:** The switch is ready for normal operation. 

14. Turn main disconnect switch to “○” off position.
15. Remove jumper wire between #7 and #19 from terminal block.
16. Reattach all wires #02 to motor contactor.
17. Reinstall any covers that was removed.
18. Remove chock or wheel blocks.
19. Proceed to Test and Verify Tilt Circuit.

Reprogramming Existing Tilt Switch

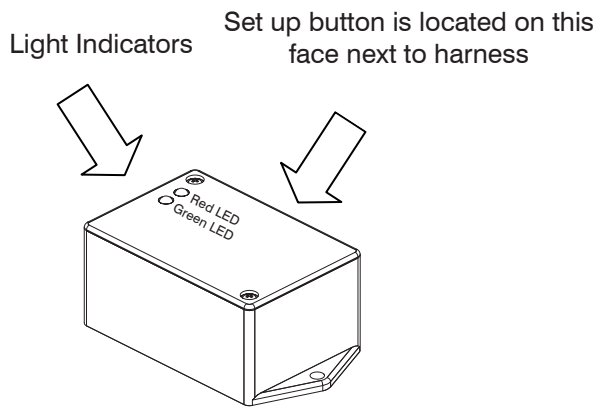

1. Ensure aerial platform is parked on a firm level surface.
2. Chock or block wheels to keep the aerial platform from rolling forward or backward.
3. Lower/Raise the platform and secure the scissors using the maintenance bar. (Refer to Operating manual for Maintenance Support Procedure)

NOTE

The tilt circuit is only powered when activating a function.

4. Remove any covers to locate and view the tilt switch.
5. Disconnect all wires #02 from motor contactor.
6. Install jumper wire between #7 and #19 to terminal strip.
7. Turn main disconnect switch to "I" ON position.
8. Verify switch is powered. (Red or green LED will be continually blinking)

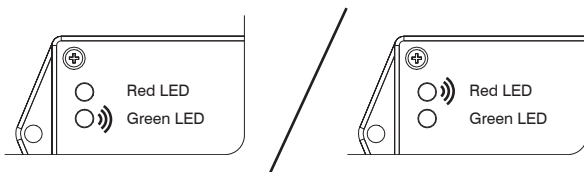

9. Reprogram the Tilt Switch

- a. Press and hold the set up button for 3 seconds. **Results:** Both LEDs will be OFF.

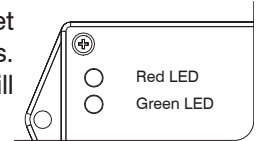

- b. Both LEDs will flash.

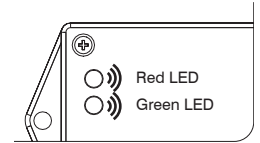

IMPORTANT

Step "c" must be completed within a 5 second period, or the switch will automatically exit program mode and return to normal operation using previously stored data.

- c. Press and release set up button 3 times.
- d. If 5 second period has expired prior completion, repeat Step "a", "b" and "c".

- e. Observe program delay / stabilization time. (Only the red LED will blink for 4 seconds)

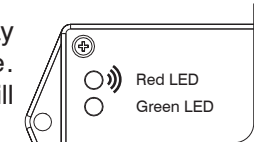

- f. Both LEDs will flash for 1 second. **Results:** The switch is learning the new zero position.

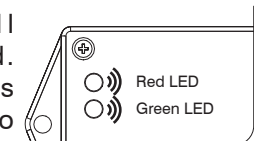

- g. Both LEDs will turn on solid for 1 second. **Results:** The new zero position has been learned.

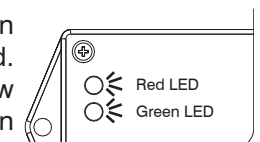

- h. The green LED will flash and then the red LED will turn on solid for 2 seconds.

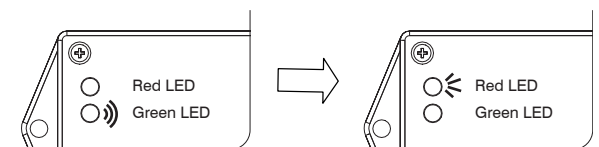

Results: The switch is verifying the new zero position.

- i. The green LED will turn on solid.
Results: The switch is ready for normal operation.

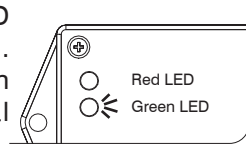

10. Turn main disconnect switch to "O" off position.
11. Remove jumper wire between #7 and #19 from terminal block.
12. Reattach all wires #02 to motor contactor.
13. Reinstall any covers that was removed.
14. Remove chock or wheel blocks.
15. Proceed to Test and Verify Tilt Circuit.

Test and Verify Tilt Circuit

Light Indicators Set up button is located on this face next to harness

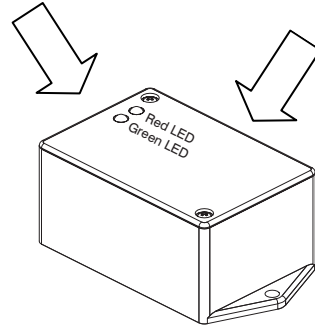

Operations of Tilt Switch

The following describes the LED's and what they indicate.

Green LED	Illuminated whenever both tilt axes are within the specified degrees of the zero/ home learned position. Flashes when transitioning in or out of tilt angle limits, but built in time delay has not fully occurred.
Red LED	Illuminated whenever tilt on one or more axes is more than the specified degrees out from the zero/ home position.
Green & Red LED	On together, no blinking when fault detected.

Tilt Circuit Test

1. Refer to section 2 for test tilt sensor procedure.

Load Sensing System - CE

5.3-1 Control Module Pin Reference Chart

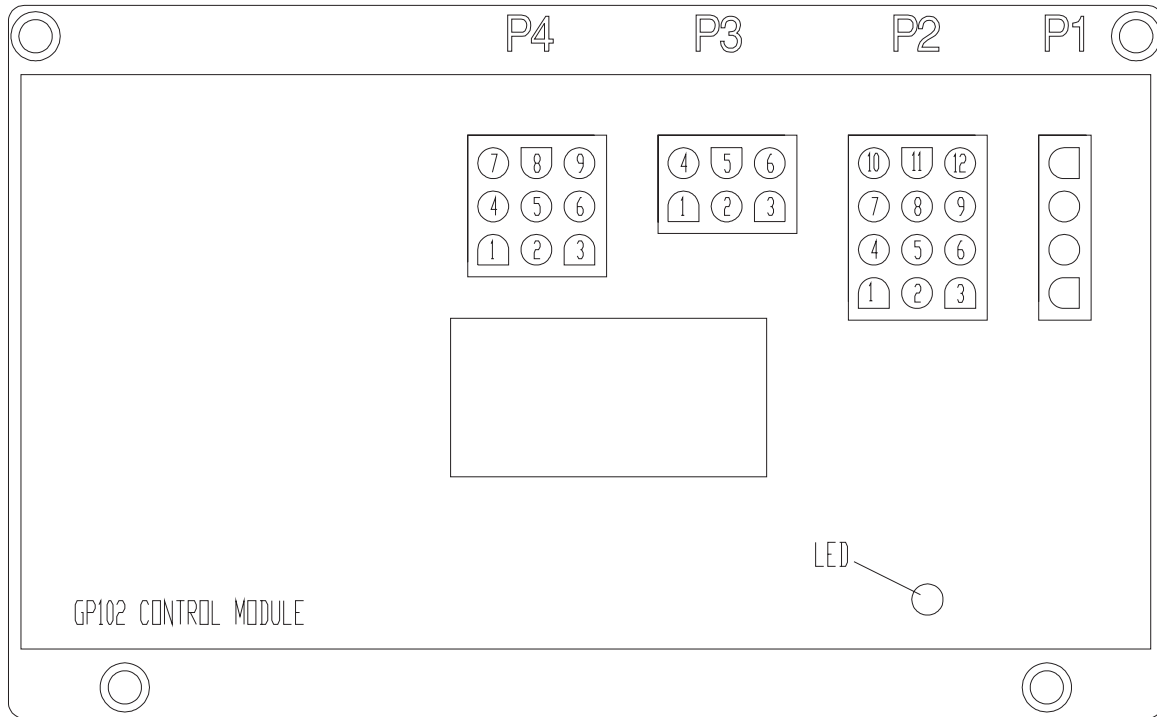

PLUG	PIN #	WIRE # AND COLOUR	WIRE FUNCTION
P1			The Calibration Connection
P2	1	Not Used	Not Used
P2	2	10E Black/White	Input Power From Base Terminal Strip To Confirm Lower Control Is Selected
P2	3	14 Black	Raise Platform Input
P2	4	13 Orange	Lower Platform Input
P2	5	Not Used	Not Used
P2	6	Not Used	Not Used
P2	7	16 White/Black	Forward Direction Input
P2	8	15 Blue	Reverse Direction Input
P2	9	Not Used	Not Used
P2	10	18B Red/Black	Input From LS1 High Speed Limit Switch To Verify ON/OFF Limits
P2	11	02 White	Negative Input From Base Terminal Strip
P2	12	7A Red	Main Power Input From Base Terminal Strip
P3	1	22 Red	Output To FL-22 Flashing Light
P3	2	29 Black	Output To BP-29 Beeper
P3	3	60 Black/White	Output To Overload Warning Light On Control Box
P3	4	28 Green/Black	Output To 28CR1 Tilt Relay And 28CR2 Down Relay
P3	5	02 White	Negative for Flashing Light and Beeper
P3	6	28E Green/White	Output To 28ECR1 Aux. Tilt Relay And 28ECR2 Aux. Down Relay
P4	1	Not Used	Not Used
P4	2	60A Green	Varied Input From Transducer
P4	3	28B Green	Varied Input From Angle Transducer
P4	4	Not Used	Not Used
P4	5	Not Used	Not Used
P4	6	910 Black	Positive Signal To Angle Transducer
P4	7	900 White	Negative Signal To Angle Transducer
P4	8	902 White	Negative Signal To Pressure Transducer
P4	9	910A Black	Positive Signal To Pressure Transducer

M60303AG

5.3-2 LED Error Codes - Quick Reference Chart

HELP Message	LED indication
EVERYTHING OK	Steady on
IN GROUND MODE!	Steady on
OVERLOAD FUNCTIONS DISABLED!	6/6
VEHICLE TILTED	1/1
VEHICLE OVERLOADED	1/2
WAITING FOR B+ ON P2-12	5/2
ARMGUARD ACTIVE!	1/3
TOO HIGH - DRIVE PREVENTED	1/4
TOO HIGH - LIFT UP PREVENTED	1/5
TESTING HWFS	7/8
IDLE TIMEOUT ACTIVE!	Always off
WAITING FOR NEUTRAL	5/5
ELEVATION SWITCH SHIFTED?	2/1
ELEVATION SWITCH STUCK?	2/2
NO LAST CALDATE!	6/3
LOAD NOT CALIBRATED	6/2
DRIVE/LIFT INPUTS FAULTY!	5/6
UP/DOWN SELECT INPUTS ACTIVE TOGETHER	5/4
INVALID LOAD - CHECK SENSORS	6/4
HEIGHT NOT CALIBRATED	6/1
INVALID HEIGHT - CHECK SENSOR	6/5
EMS INPUTS FAULTY!	5/2
B+ SUPPLY TOO LOW	5/1
P4-1 OR P5-1 SHORT TO 0V?	4/1
P3-4 SHORT TO SUPPLY!	4/2
P3-4 SHORT TO 0V?	4/3
P3-4 SHORT TO SUPPLY?	4/4
P3-6 SHORT TO 0V?	4/5
P3-6 SHORT TO SUPPLY?	4/6
FAULT: BAD TILT SENSOR	7/1
FAULT: BAD HWFS	7/2
FAULT: BAD SLAVE ANALOGS	7/3
FAULT: BAD STRAIN MONITORS	7/4
FAULT: BAD SLAVE MICRO	7/5
FAULT: HWFS STALLED!	7/6
STARTUP!	7/7
FACTORY OVERRIDE	6/7

60405AA

Reading the Codes:

In order to read the fault codes, a sequence of pauses and flashes can be seen on the LED mounted on the GP102 module. The codes are continuously displayed by the LED until the fault is cleared, the GP102 reset and no longer detects the fault, or idle timeout becomes active.

The sequence is as follows:

1. Quarter second flashes followed by quarter second pauses indicate the first digit.
2. A 1.5 second pause.
3. Quarter second flashes followed by quarter second pauses indicate the second digit
4. A 4 second pause. Repeat steps 1-4

Since the GP102 only reports one error, only one code can be read from the LED per instance. If the error is cleared and another error is present, it will then be presented.

5.3-3 LED Error Codes - Code Breakdown Chart

Diagnostic sequence dependant on LED flash code:

No Last Caldate	63
Load Not Calibrated	62
Height Not Calibration	61

An EZcal is required!

Waiting For Neutral	55
Drive/Lift Inputs Faulty!	56
Up/Down Select Inputs Active Together	54
EMS Inputs Faulty!	52

Check inputs on P2 pins 1,2,3,4,5,6,7,8.

P3-4 Short To Supply!	42
P3-4 Short To Supply?	44
P3-6 Short To Supply?	46

Disconnect plug P3. If fault clears there is a problem with the wiring from P3-4 or P3-6 to the rest of the vehicle.

Armguard Active!	23
Elevation Switch Shifted?	21
Elevation Switch Stuck?	22

If the 23 flash code is triggered by armguard, it will occur once then clean. This is not a true fault but just an indication of the reason for the vehicle stop. If the 21 or 22 flash code is triggered by a fault with the elevation switch, it will not clear. Check that the elevation switch correctly opens/closes when the platform is raised/lowered.

P3-4 Short To 0V?	43
P3-6 Short To 0V?	45

Disconnect plug P3. If fault clears there is a wiring fault from P3-4 or P3-6 to the rest of the vehicle.

Invalid Load - Check Sensors	45
------------------------------	----

Check the voltage out of the pressure transducer, into P4-2. It should be between 0.5V (zero pressure) and 4.5V (maximum pressure) and should vary as the platform load & position varies.

Waiting For B+ on P2-12	52
B+ Supply Too Low	51
P4-1 Or P5-1 Short To 0V?	41

Check that the battery voltage is not too low.

Verify battery voltage on P2-12.

Disconnect plug P4 – if the fault clears there is a wiring fault from P4-1 to the rest of the vehicle.

5.3-3 LED Error Codes - Code Breakdown Chart (Continued)

Vehicle Tilted	11
Vehicle Overloaded	12
Too High - Drive Prevented	14
Too High - Lift Up Prevented	15

These are not true faults but an indication that vehicle movement is prevented. Remove excessive load from the platform. Lower the platform if close to maximum height. Move the vehicle to level ground.

Invalid Height - Check Sensor	65
-------------------------------	----

Check the voltage out of the height transducer, into P4-3. It should be between .4V and 4.6V and should vary as the platform position varies.

Testing HWFS	78
Start Up!	77

These are not true faults unless they do not clear – the start-up tests should only occur for a short time.

Overload Functions Disabled!	66
Factory Override	67

These are not true faults – the GP102 has been configured to suppress overload functionality.

Idle Timeout Active!	Always Off
Fault: Bad Tilt Sensor	71
Fault: Bad HWFS	72
Fault: Bad Slave Analogs	73
Fault: Bad Strain Monitors	74
Fault: Bad Slave Micro	75
Fault HWFS Stalled!	76

Action a function to clear the idle timeout if it occurred. Ensure the GP102 is correctly mounted – incorrect mounting can cause the “bad tilt sensor” diagnostic to occur. Otherwise there may be an internal problem with the GP102.

5.3-4 Hand Held Calibration/Diagnostic Tool Key Functions



WARNING





Only trained and authorized personnel shall be permitted to service and aerial platform.

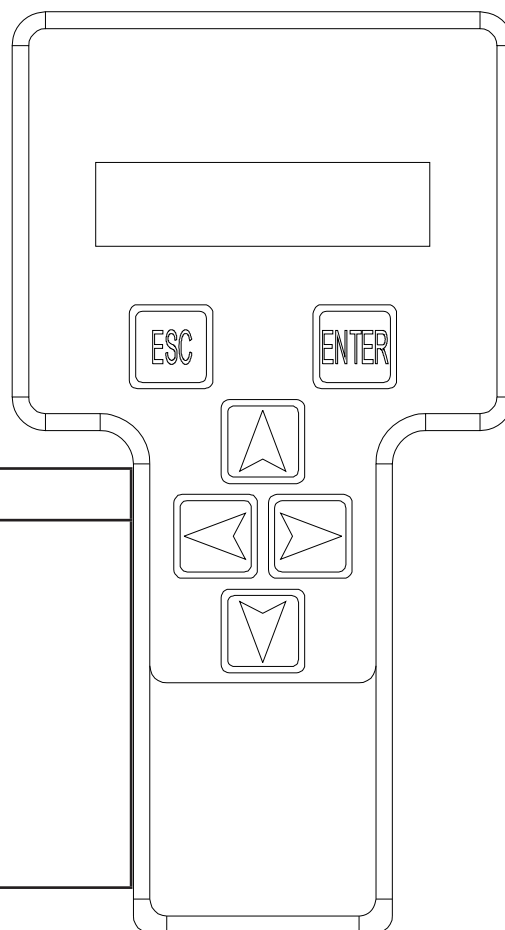

WARNING

Read all instructions closely before attempting each phase or the calibration procedure.

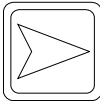

Symbol	Key Function
 	<p>ESC/ENTER Buttons To move back and forth between menu and sub-menu</p>
 	<p>LEFT/RIGHT Buttons Select menus and setting to be adjusted</p>
 	<p>UP?DOWN BUTTONS Adjust setting values</p>

5.3-5 Control Module Load Calibration - Code Messages & Definitions

During calibration the following failure message may appear:

F01: Check HWFS

- This message is given if the GP102 startup tests have not completed. Check HELP message for more information.

F02: Not Ground Mode

- This message is given if the machine is not in ground mode (P2-2 must be high). Calibration can only be carried out in ground mode.

F03: Not Stopped

- This message is given if any function switch is closed. Check DIAGNOSTICS / SWITCHES to see which function switch is closed.

F04: Tilted

- This message is given if the machine is tilted. Calibration must be carried out with the machine level. If the machine is level, use the SETUPS / TILT SETUPS to set the GP102 level.

F05: Bad Height

- This message is given if the height sensor output (P4-3) is out of range at the start of calibration. The height sensor output must be between 0.9V and 4.1V. Check DIAGNOSTICS / SENSORS to see the output. A reading of 0V or 5V is probably due to a wiring problem.

F06: Check Elev

- This message is given if the elevation switch (P210) is open at the start of calibration, when the operator has confirmed the "PLATFORM DOWN?" question. If the platform is down, check the elevation switch wiring.

F08: Check Elev

- This message is given if the elevation switch (P2-10) is closed at the end of calibration, when the platform should be fully raised. This message would occur if the UP switch was accidentally opened near the start of the lift. If the platform is fully raised, check the elevation switch wiring.

F09: Bad Height

- This message is given if the height sensor output (P4-3) is out of range at the start of calibration. The height sensor output must be between 0.9V and 4.1V. Check DIAGNOSTICS / SENSORS to see the output.

F10: Bad Height

- This message is given if the height sensor output (P4-3) is out of range at the end of calibration. The height sensor output must be between 0.9V and 4.1V. Check DIAGNOSTICS / SENSORS to see the output. A reading of 0V or 5V is probably due to a wiring problem.

F11: Not Up

- This message occurs at the start of calibration if the operator selects a function other than UP.

F13: Low Height Range

- This message occurs at the end of calibration if the height sensor output did not change sufficiently to give a reasonably accurate platform height estimate. DIAGNOSTICS / SENSORS can be used to check the height sensor output (P43) when the platform is fully lowered and fully raised; a difference of at least 1V is to be expected. This message could occur if the UP switch was accidentally opened too early (when the platform is not fully raised).

F15: Check Elev

- This message is given if the elevation switch (P2-10) is open when the platform has been fully lowered at the end of calibration. This message would occur if the DOWN switch was accidentally opened before the platform was fully lowered. If the platform is fully lowered, check the elevation switch.

F16: Low Elev.open

- This message is given if the elevation switch (P2 10) opened during lift at a too low height (below 5%). Check CALIBRATIONS / HEIGHT CALS; the "ElevUp" value shows the recorded height where the switch opened.

F17: High Elev.open

- This message is given if the elevation switch (P210) opened during lift at a too high height (above 25%). Check CALIBRATIONS / HEIGHT CALS; the "ElevUp" value shows the recorded height where the switch opened.

F18: Low Elev.close

- This message is given if the elevation switch (P210) closed during lower at a too low height (below 5%). Check CALIBRATIONS / HEIGHT CALS; the "ElevDown" value shows the recorded height where the switch opened.

F19: High Elev.close

- This message is given if the elevation switch (P210) closed during lower at a too high height (above 25%). Check CALIBRATIONS / HEIGHT CALS; the "ElevUp" value shows the recorded height where the switch opened.

F20: Height<>0%

- This message occurs if the platform height is not 0% after the platform has been fully lowered at the end of calibration. The platform must return to the same height each time it is fully lowered. Check DIAGNOSTICS / SYSTEM to check the height.

F28: Bad Height

- This message indicates a problem with the height sensor output (P43) during calibration. The height sensor output must be between 0.9V and 4.1V during calibration and between 0.4v and 4.6v during normal operation. Check DIAGNOSTICS / SENSORS to see the output. A reading of 0V or 5V is probably due to a wiring problem.

F42: Low Pressure

- This message indicates that the pressure is too low (0.5V or less) when the elevation switch opens during calibration. Check DIAGNOSTICS / SENSORS to check the pressure.

F43: High Pressure

- This message indicates that the pressure is too high (4.5V or more) when the elevation switch opens during calibration. Check DIAGNOSTICS / SENSORS to check the pressure.

F44: Low Pressure

- This message indicates that the pressure is too low (0.5V or less) at a measurement point. Check DIAGNOSTICS / SENSORS to check the pressure.

F45: High Pressure

- This message indicates that the pressure is too high (4.5V or more) at a measurement point. Check DIAGNOSTICS / SENSORS to check the pressure.

F46: Check Elev

- This message indicates that the elevation switch opened more than once during calibration lifting.

F47: Check Elev

- This message indicates that the elevation switch closed more than once during calibration lowering.

F48: Bad Pressure

- This message is given if the pressure sensor output (P4-2) is out of range at the start of calibration. The height sensor output must be between 0.5V and 4.5V. Check DIAGNOSTICS / SENSORS to see the output. A reading of 0V or 5V is probably due to a wiring problem.

F52: Too Few!

- This message indicates that not enough measurements were recorded during calibration lifting or lowering.

F98: Out of Range

- This message indicates that the “fine tune” calibration is unacceptable. This probably is due to the wrong load being in the platform (i.e: specifying “EMPTY” if the platform is loaded, or the other way round) or (Having the incorrect pressure transducer installed).

During calibration the following information messages may appear:**Caldate:**

- This message is prompting for the date to be entered; it is stored to identify when the machine was calibrated. The last calibrate date can be viewed in DIAGNOSTICS / LOG. Press LEFT & RIGHT to select the flashing digits. Press UP & DOWN to change the flashing digits. Press ENTER when the entry is complete. IMPORTANT: The date 00/00/00 is not allowed!

Finished

- This message confirms that calibration is complete and successful.

Lift Empty

- This message is displayed while the platform is being raised to the next measurement height, when an EMPTY platform is being calibrated.

Lift Loaded

- This message is displayed while the platform is being raised to the next measurement height, when a LOADED platform is being calibrated.

Lifting

- This message is displayed while the platform is being raised, during HEIGHT-only calibration.

Lower Empty

- This message is displayed while the platform is being lowered to the next measurement height, when an EMPTY platform is being calibrated.

Lower Loaded

- This message is displayed while the platform is being lowered to the next measurement height, when an EMPTY platform is being calibrated.

Lowering

- This message is displayed while the platform is being lowered, during HEIGHT-only calibration.

Measuring #

- This message is displayed when the platform is stopped during calibration, when the GP102 takes a measurement. There will be a short delay while the machine is allowed to stabilize after movement is stopped.

Must Go Down!

- This message occurs if the wrong switch is closed when the GP102 is waiting for the platform to be lowered.

Must Go Up!

- This message occurs if the wrong switch is closed when the GP102 is waiting for the platform to be raised.

Platform Down?

- This message is prompting for confirmation that the platform is fully lowered. If necessary the DOWN switch can be activated to lower the platform. Press ENTER to confirm when the platform is fully lowered.

Platform Empty?

- This message is prompting for confirmation that the platform is completely empty. Press ENTER to confirm if the platform is empty.

Platform Loaded?

- This message is prompting for confirmation that the platform is loaded to rated load. Press ENTER to confirm if the platform is loaded.

Please Lift

- This message is prompting for the platform to be raised. The UP switch should be closed.

Please Lower

- This message is prompting for the platform to be lowered. The DOWN switch should be closed.

Please Wait

- This message indicates that the GP102 is busy; the delay will be short (no more than 5s).

Total Data:

- This message is displayed at the end of each phase, to confirm the number of measurements recorded by the GP102.

5.3-6 Control Module Load Calibration Procedure

1. Move the aerial platform to a test area where the platform can be elevated to its maximum working height and reach.
2. Ensure the aerial platform is parked on a firm, level surface.

IMPORTANT

Each phase must be completed before the next phase can be carried out.
All phases must be completed before the aerial platform can be operated.

IMPORTANT

Always follow the instructions of the Calibration instrument.

IMPORTANT

Make sure the aerial platform is on BASE mode.

NOTE

To ensure a good and clear contact, clean the wire terminals before attaching the jumper clip.

3. Locate the main manifold inside the hydraulic/electric tray.
4. Disconnect the black wire #14 from the lift coil.
5. Locate the contactor on the electrical panel assembly.
6. The jumper connection must be connected between the contractor (wire #19B) and the lift coil (instead of the black wire #14)

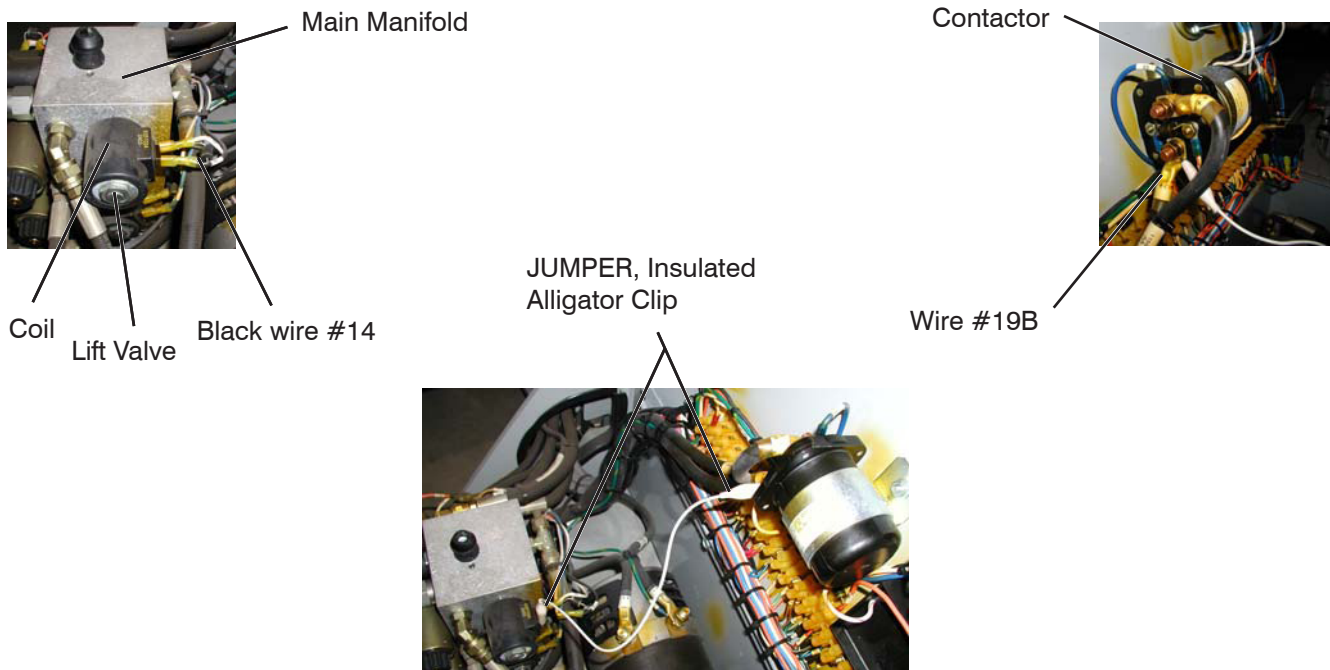

7. Connect the Easy-Cal tool to the P1 connector on the CONTROL MODULE.

8. The display will show "**Help: Press Enter**".
By using Left/Right buttons, select the "Access Level (?)" from the menu and press the **ENTER** button.

Contact Skyjack Service Department at:
(44) 1691-676 236 for your Access Level Code Number.
9. The display will show "**Access Level Code (xxxx)**".
By using the Up/Down buttons, enter the Access Level Code (xxxx) followed by pressing the **ENTER** button.
10. The display will show "**Access Level 2**".
By using Left/Right buttons, select the "Setups" from the menu and press the **ENTER** button.
11. The display will show "**Machine Defaults**".
Select the "Machine Defaults" from the menu and press the **ENTER** button.
12. The display will show "**Defaults, 0 = Custom**".
By using Left/Right buttons, select the "**X = Group Code**" from the menu and press the **ENTER** button.
13. The display will show "**X=GROUP CODE**". (Refer to 5.3-8 for group code)
By using the Up/Down buttons, enter the "Group Code (?)" then by using Left/Right buttons, select the "**Curve**" from the menu.
14. The display will show "**X=CURVE**". (Refer to 5.3-8 for curve code)
By using the Up/Down buttons, enter the "Curve Code (?)" followed by pressing the **ESCAPE** button.
15. The display will show "**Machine Defaults**".
By using Left/Right buttons, select the "Tilt Setups" from the menu and press the **ENTER** button.
16. The display will show "**Tilt Setups: Calibrate Level**".
Select the "**Tilt Setups: Calibrate Level**" from the menu and press the **ENTER** button.
17. The display will show "**Calibrate Level: Yes: Enter, No: ESC**".
Select the "Yes" from the menu by press the **ENTER** button.
18. The display will show "**Calibrate Level: Tilt 0.0' , 0.0'**".
Select the "**ESCAPE**" from the menu once.
19. The display will show "**Tilt Setups Calibrate Level**".
Select the "**ESCAPE**" from the menu once again.
20. The display will show "**Setups Tilt Setups**".
By using Left/Right buttons, select the "Load Setups" from the menu and press the **ENTER** button.
21. The display will show "**Load Setups: Calibrate Load**".
Select the "**Load Setups: Calibrate Load**" from the menu and press the **ENTER** button.
22. At this point, elevate the aerial platform at full height, check the harness and making sure it is not stretched tight, then lower down the platform.
23. The display will show "**Calibrate Load: Platform Down?**".
Asking for confirmation that the platform is fully lowered?
Check that the platform is fully lowered then press the **ENTER** button to confirm.

24. The display will show "**Calibrate: Loaded Empty? No**".
Asking for confirmation that the platform is empty?
Check that the platform is empty
25. By using the Up/Down buttons, enter the "Yes" followed by pressing the **ENTER** button.
26. The display will show "**Calibrate Load: Please Lift.....**".
Waiting for the lift switch to be activated.
27. Hold the lift switch and keep holding it until the platform is fully elevated.

IMPORTANT

If the lift switch is released earlier than full-height position, the calibration will have to be aborted and repeated from the beginning!

28. When the system detects the lift switch closed, the display will show "**Calibrate Load: Lift Empty**".
29. After a delay, the system will stop the platform lifting and will take height & pressure measurements; the display will show "**MEASURING # xx**". When the measurements have been taken, the platform will resume lifting.

NOTE

The Lifting.....stopping.....measuring....lifting process will continue until the platform reaches full height.

30. When the platform reaches full height release the lift switch.
31. The display will briefly show "**TOTAL DATA: 04**" to indicate the number of measurements taken.
32. The display will show "**Calibrate Load: Please Lower.....**".

IMPORTANT

If the lower switch is released earlier than full-lower position, the calibration will have to be aborted and repeated from the beginning!

33. Hold the lower switch and keep holding it until the platform is fully lowered.
34. When the system detects the lower switch closed, the display will show "**Calibrate Load: Lower Empty**".
35. After a delay, the system will stop the platform lowering and will take height & pressure measurements; the display will show "**MEASURING #xx**". When the measurements have been taken, the platform will resume lowering.

NOTE

The lowering.....stopping.....measuring....lowering process will continue until the platform is fully lowered.

36. When the platform is fully lowered (and height 0% is displayed), release the lower switch.
37. The display will show briefly "**TOTAL DATA: 04**" to indicate the number of measurements taken.
38. The display will show "**Calibrate Load: Caldate: mm/dd/yy**".
It is recommended that the current date be entered here to provide easy taking of the data of last calibration.
The current date must be entered using the **LEFT/RIGHT** and **UP/DOWN** buttons.

39. Press ENTER to complete date entry (the system will store it).
40. The display will show “**Calibrate Load**” option.
41. Press the ESC button to exit the “**Calibrate Load**” option.
42. Remove the jumper wire and re-connect the black wire #14 to the coil removed earlier.
43. Close the hydraulic/electric tray.

NOTE

Continuing partially complete load calibration.

Once a calibration phase has been successfully completed, it is not required to do it again (unless of course a change to the vehicle such as a replacement sensor requires that calibration be repeated). This is useful if the calibration procedure is interrupted – the remaining phases can be completed at a later time.

If a calibration phase has been successfully completed, a “**REDO**” message is displayed:

REDO DYNAMIC: NO

REDO LOADED: NO

REDO EMPTY: NO

If the phase does not need to be repeated, just press **ENTER** to move on.

If the phase does need to be repeated, press **UP** or **DOWN** to change “**NO**” to “**YES**” then press **ENTER**.

5.3-7 Curve/Group Codes Chart

Model	Number of Extension Platforms	Curve Code	Group Code
3215	1 Manual Extension Platform	1	3
3219	1 Manual Extension Platform	2	3
3220	1 Manual Extension Platform	3	3
3220	1 Powered Extension Platform	4	3
3226	1 Manual Extension Platform	5	3
4620	1 Manual Extension Platform	8	3
4620	1 Powered Extension Platform	9	3
4626	1 Manual Extension Platform	12	3
4626	1 Powered Extension Platform	13	3
4632	1 Manual Extension Platform	14	3
6826	1 Manual Extension Platform	16	5
6826	1 Powered Extension Platform	17	5
6832	1 Manual Extension Platform	20	6
6832	1 Powered Extension Platform	21	6

60404AD1

SKYJACK™

www.skyjack.com